



HESTORE.HU

elektronikai alkatrész áruház

EN: This Datasheet is presented by the manufacturer.

Please visit our website for pricing and availability at www.hestore.hu.

AR-GSM-S2

SIM900 GSM Shield for Arduino development boards, 4 band GSM + GPRS

HESTORE Part no.: 1003.9035

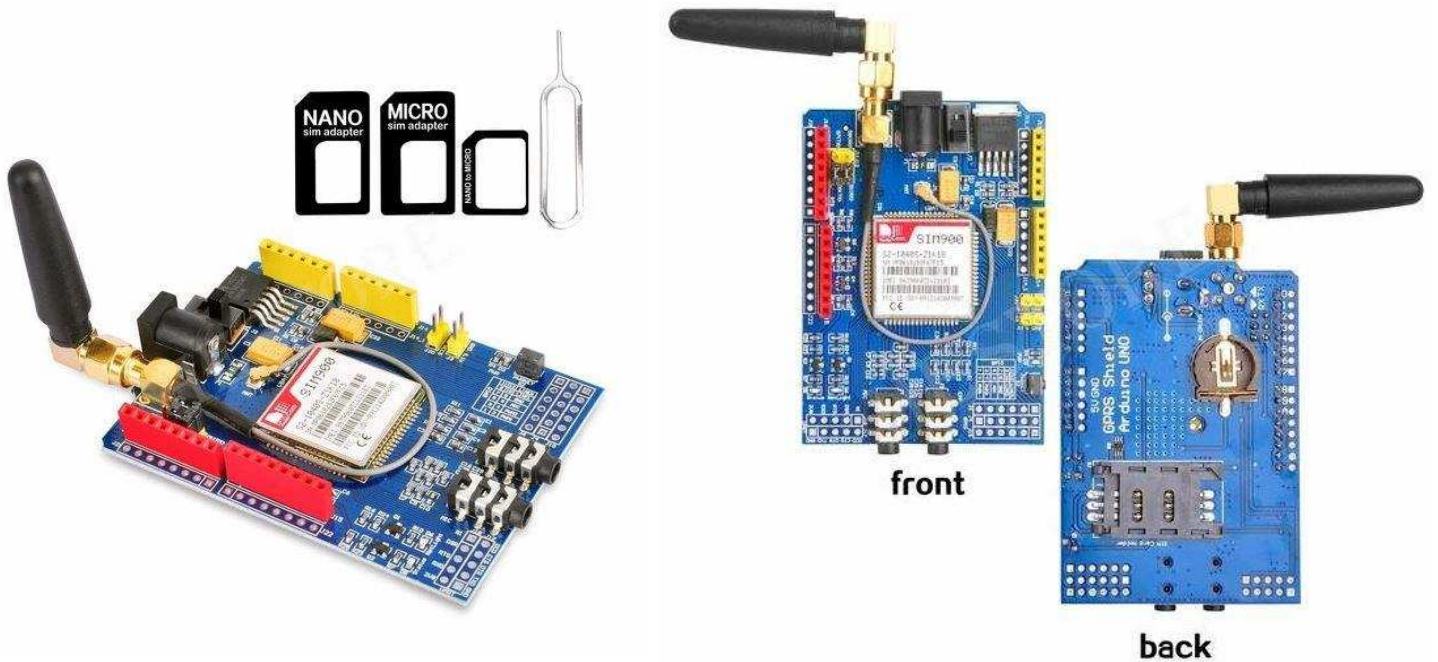

Technical specifications

Power supply range:	5...9V DC
Power consumption:	max. 2A
Bandwidth:	850/900/1800/1900Mhz
Transmit Power:	Class 4 (2W) at GSM850 and EGSM900 Class 1 (1W) at DCS1800 and PCS1900
SIM card:	Full size
Antenna connector:	SMA and U.FL
Make and receive:	voice calls using an external earphone & electret microphone
Send and receive:	SMS messages GPRS data (TCP/IP, HTTP, etc.)
Scan and receive:	FM radio broadcasts

Overview

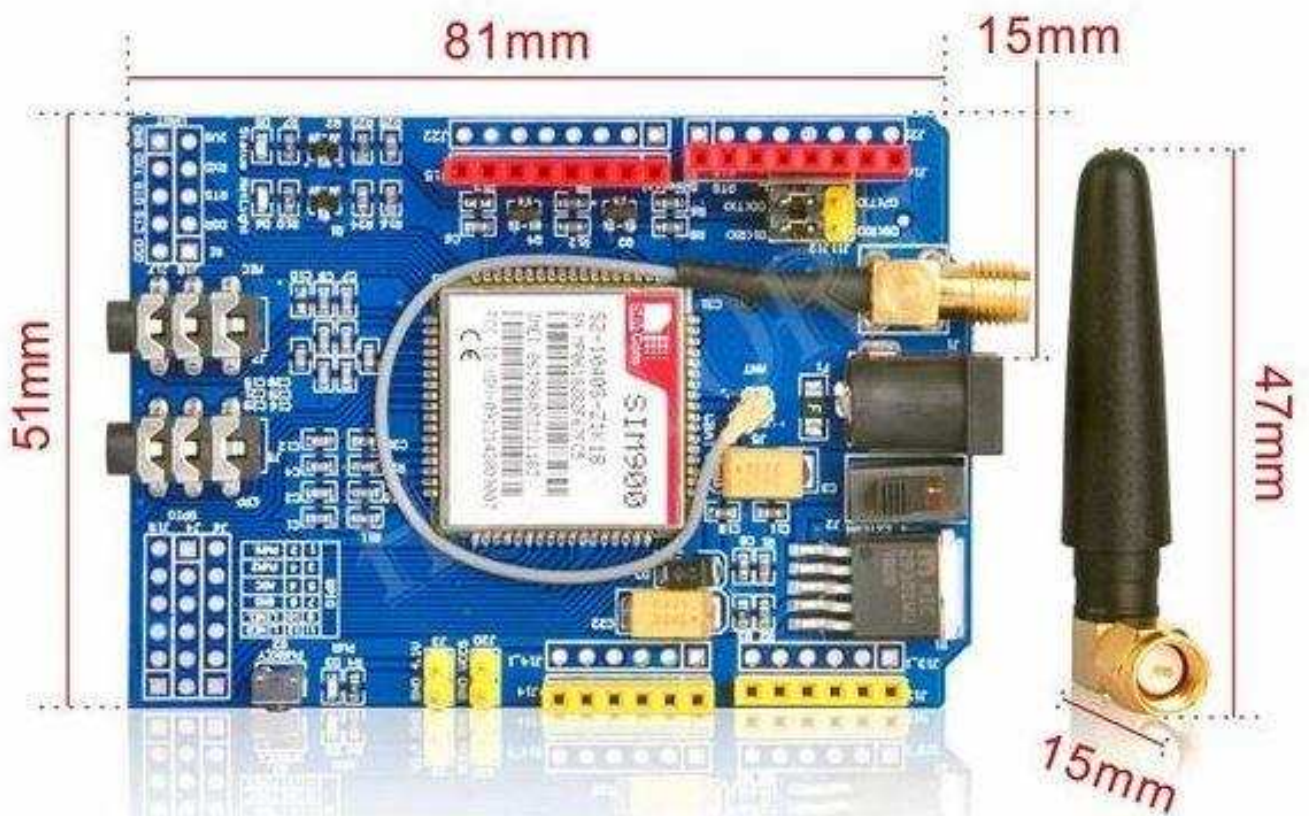
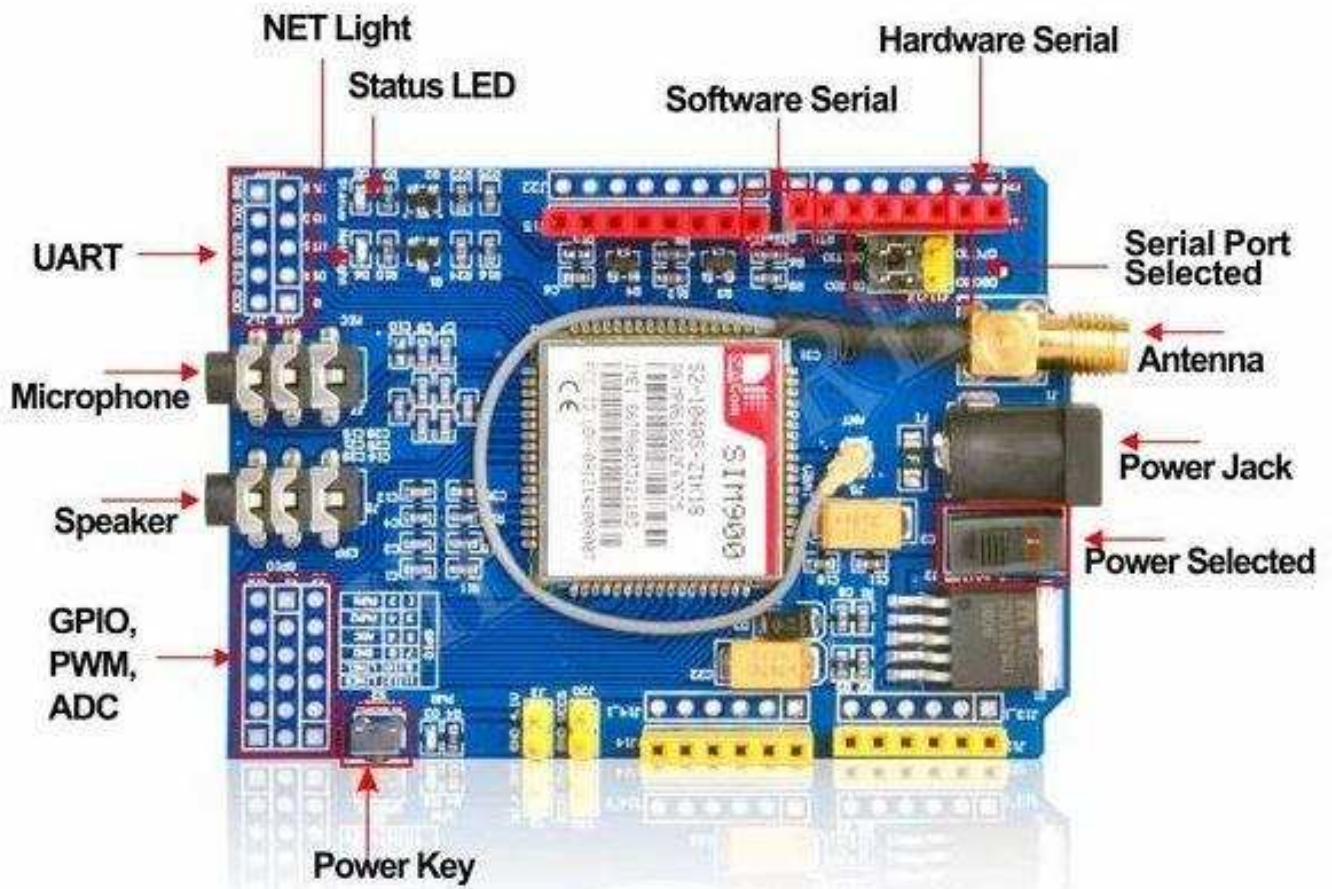

Supplying Power for SIM900 Shield

The operating voltage of SIM900 chip is from 3.4V to 4.4V. To keep supply voltage safe at 4.1V, the shield comes with a high current, high accuracy, low-dropout voltage regulator MIC29302WU from Micrel – capable of handling load currents up to 3A.

You can add an external power supply to the shield with the 5.5mm DC jack, to which you can connect any 5V-9V DC minimum 2A wall adapter you have. Next to the DC jack, is a Slide Switch to select the power source labeled EXTERN. To use external power source, move the slider as shown.



UART Communication

The SIM900 GSM/GPRS shield uses UART protocol to communicate with an Arduino. The chip supports baud rate from 1200bps to 115200bps with Auto-Baud detection.

With the help of jumpers you can connect (RX,TX) of the shield to either Software Serial(D8,D7) or Hardware Serial(D1,D0) of the Arduino.

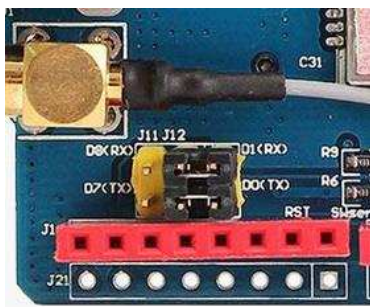

Software Serial selected



Hardware Serial selected

Speaker & Microphone

The shield comes with two standard 3.5mm jacks. One for stereo earphone and other for mono microphone. It allows you to use SIM900's audio interface to make and receive voice calls and listen FM radio.

Antenna

An antenna is required to use the SIM900 for any kind of voice or data communications as well as some SIM commands. The shield has two interfaces for connecting antenna viz. a U.FL connector and a SMA connector. They are connected through a patch cord. The shield usually comes with a 3dBi GSM antenna and allows you to put the shield inside a metal case(as long the antenna is outside).



SIM Socket

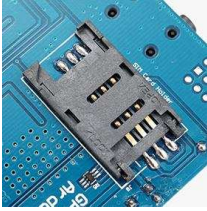

There's a SIM socket on the back. Any activated, 2G full-size SIM card would work perfectly. The workings of the SIM card socket can take some getting used to. To unlock the latch, push the top part of the assembly, and then lift it up. Place the SIM card into the bottom part of the socket. Then fold the arm back into the body of the socket, and gently push it forward towards the LOCK position.

RTC(Real Time Clock)

The SIM900 shield can be configured to keep time. So there is no need for any separate RTC. This will keep the time even when the power is OFF. If you want to use internal RTC, you need to install CR1220 battery at the back side of the shield.

Your network provider may not support setting the time automatically. In that case you can do it manually using AT+CCLK AT command.

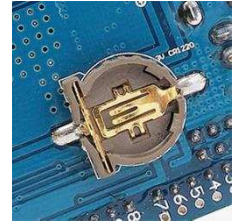

Made in PRC, distributed by HESTORE Hungary Ltd. in EU.

<https://www.hestore.hu/>