



HESTORE.HU
elektronikai alkatrész áruház

EN: This Datasheet is presented by the manufacturer.

Please visit our website for pricing and availability at www.hestore.hu.

H
G
F
E
D
C
B
A

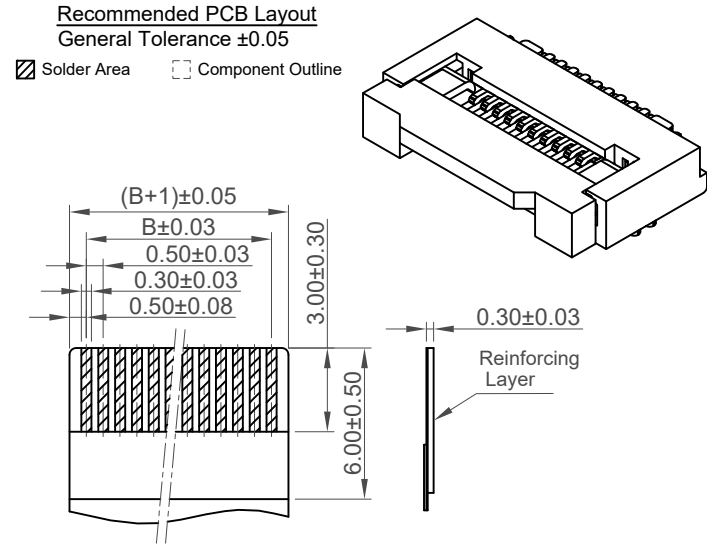
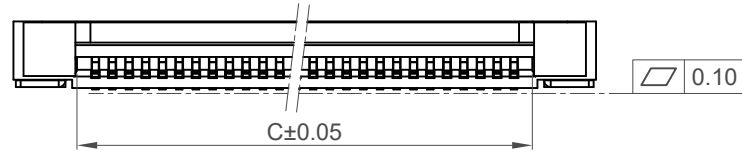
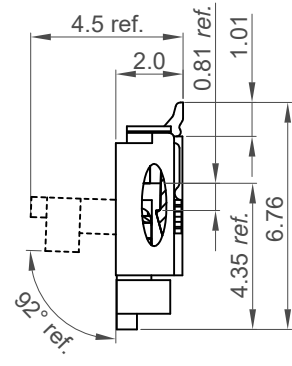
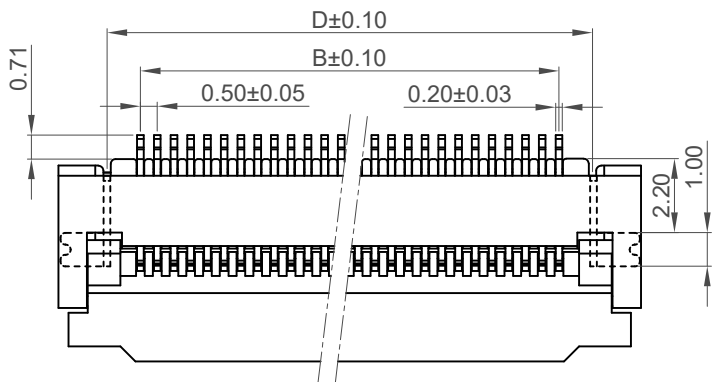
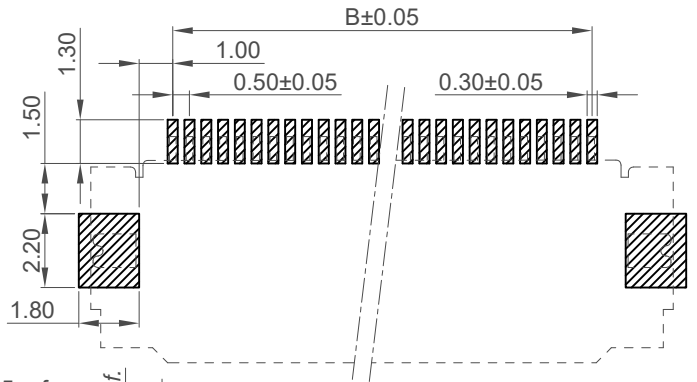
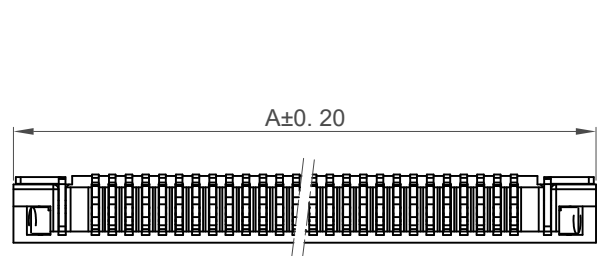

No. of Contacts	Dimensions			
	A	B	C	D
* 4	6.4	1.50	2.60	3.50
* 5	6.9	2.00	3.10	4.00
* 6	7.4	2.50	3.60	4.50
* 7	7.9	3.00	4.10	5.00
* 8	8.4	3.50	4.60	5.50
* 9	8.9	4.00	5.10	6.00
* 10	9.4	4.50	5.60	6.50
* 11	9.9	5.00	6.10	7.00
* 12	10.4	5.50	6.60	7.50
* 13	10.9	6.00	7.10	8.00
* 14	11.4	6.50	7.60	8.50
* 15	11.9	7.00	8.10	9.00
* 16	12.4	7.50	8.60	9.50
* 17	12.9	8.00	9.10	10.00
* 18	13.4	8.50	9.60	10.50
* 19	13.9	9.00	10.10	11.00
* 20	14.4	9.50	10.60	11.50
* 21	14.9	10.00	11.10	12.00
* 22	15.4	10.50	11.60	12.50
* 23	15.9	11.00	12.10	13.00
* 24	16.4	11.50	12.60	13.50
* 25	16.9	12.00	13.10	14.00
* 26	17.4	12.50	13.60	14.50
* 27	17.9	13.00	14.10	15.00
* 28	18.4	13.50	14.60	15.50
* 29	18.9	14.00	15.10	16.00
* 30	19.4	14.50	15.60	16.50
* 31	19.9	15.00	16.10	17.00
* 32	20.4	15.50	16.60	17.50
* 33	20.9	16.00	17.10	18.00
* 34	21.4	16.50	17.60	18.50
* 35	21.9	17.00	18.10	19.00
* 36	22.4	17.50	18.60	19.50
* 37	22.9	18.00	19.10	20.00
* 38	23.4	18.50	19.60	20.50
* 39	23.9	19.00	20.10	21.00
* 40	24.4	19.50	20.60	21.50
* 41	24.9	20.00	21.10	22.00
* 42	25.4	20.50	21.60	22.50
43	25.9	21.00	22.10	23.00
44	26.4	21.50	22.60	23.50
* 45	26.9	22.00	23.10	24.00
* 46	27.4	22.50	23.60	24.50
47	27.9	23.00	24.10	25.00
48	28.4	23.50	24.60	25.50
49	28.9	24.00	25.10	26.00
* 50	29.4	24.50	25.60	26.50
* 51	29.9	25.00	26.10	27.00
52	30.4	25.50	26.60	27.50
* 53	30.9	26.00	27.10	28.00
* 54	31.4	26.50	27.60	28.50
* 55	31.9	27.00	28.10	29.00
56	32.4	27.50	28.60	29.50
57	32.9	28.00	29.10	30.00
58	33.4	28.50	29.60	30.50
59	33.9	29.00	30.10	31.00
* 60	34.4	29.50	30.60	31.50

Specification:

Material:

Housing: LCP, UL 94V-0, Natural
 Actuator: LCP, UL 94V-0, Black
 Contact: Phosphor Bronze
 Fitting Nail: Brass

Plating:

Contact: See Ordering Grid
 Fitting Nail: Matte Tin

Electrical:

Voltage Rating (Max.): 50V AC/DC
 Current Rating (Max.):
 0.4A AC/DC (60 contacts powered)
 0.5A AC/DC (40 contacts powered)
 Dielectric Strength: 250V AC for 1 minute
 Insulation Resistance: 50 MΩ Min.
 Contact Resistance: Initial: 30 mΩ Max.
 Final: 50 mΩ Max.

Mechanical & Environmental

Durability: 30 Cycles
 Operating Temperature: -25°C to +85°C
 Solder Profile:
 Peak Temp 260°C (+0/-5°C) max. (5 seconds)

Ordering Grid
FFC2B35 = **XX** - **X** Request Samples and Quotation Halogen Free

No. of Contacts: 04 - 60 (see dimension table)
 Contact Plating: **G** = Gold Flash over all (Standard), **T** = Tin Plating over all

* = Tooled Parts
 Please contact GCT for non-tooled parts

Part Number		Product Description	
FFC2B35		FFC/FPC 0.5mm Pitch Side Entry, Bottom Contact, SMT, Height=2.0mm, Front Flip	
Drawing Date		11th June 2021	
By	CC	Tolerances (Except as Noted)	Units:
Detail	Drawing Release	Length	Metric (mm)
Revision	A2	XX ± 0.20	
Date	10/01/22	X.XX ± 0.10	

GCT
 www.gctco

This drawing is confidential and copyright of Global Connector Technology, Ltd (GCT). This drawing must not be copied or disclosed without written consent. E & OE

Not to Scale | Drawn By CC | Sheet No. 1/2

H
G
F
E
D
C
B
A

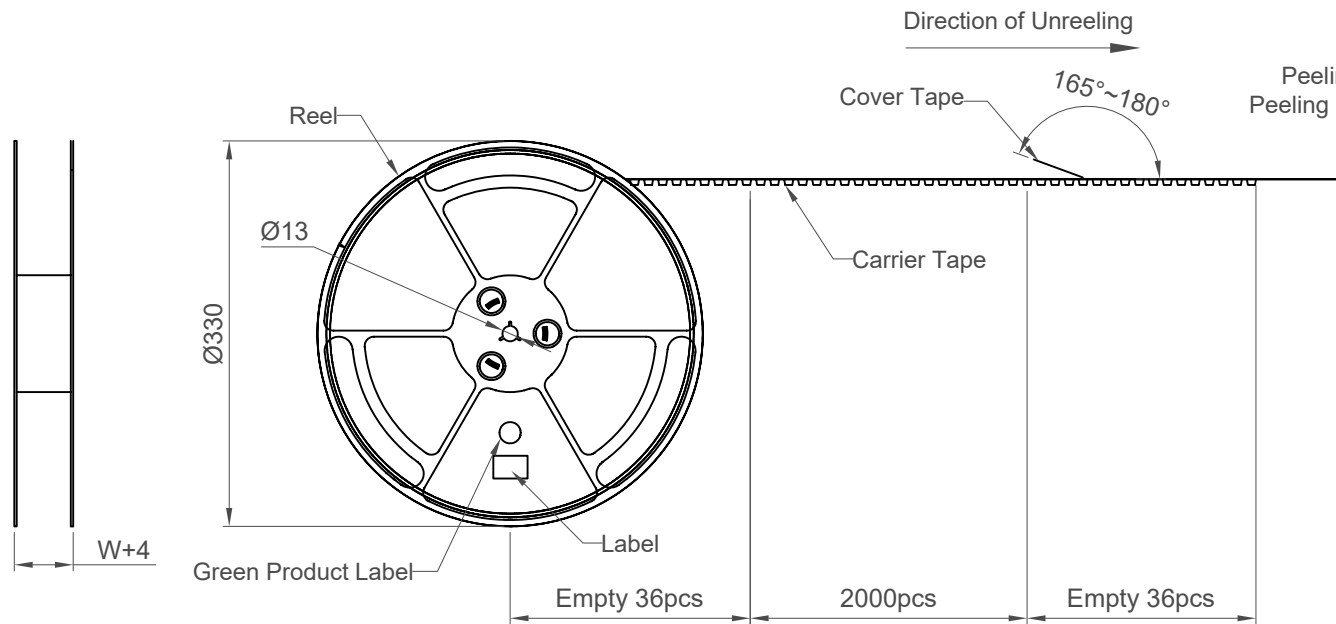

Peeling angle: 165°~180°
Peeling strength: 0.3 ~ 0.9 N

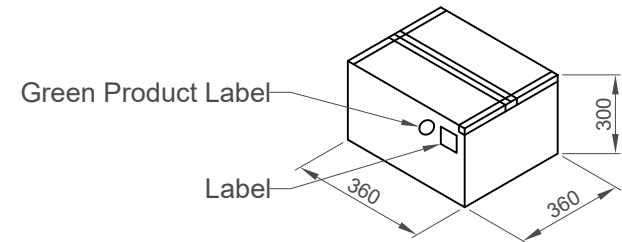
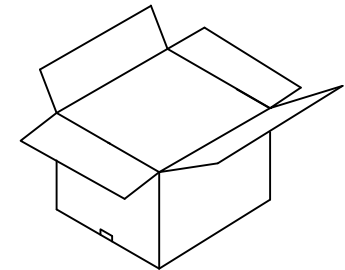
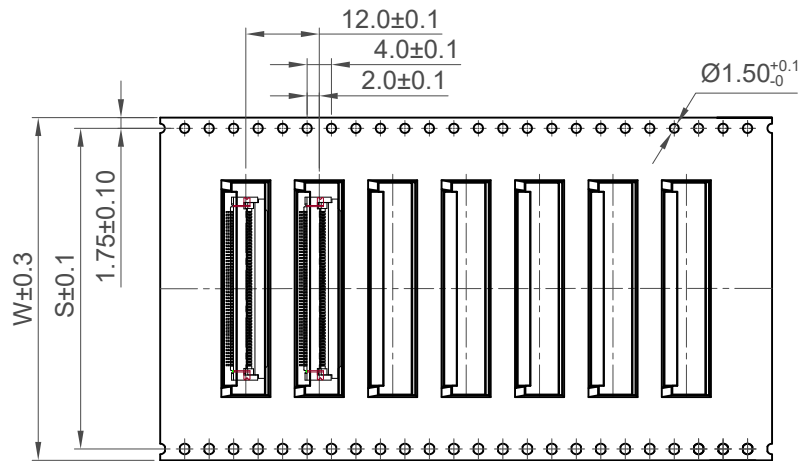
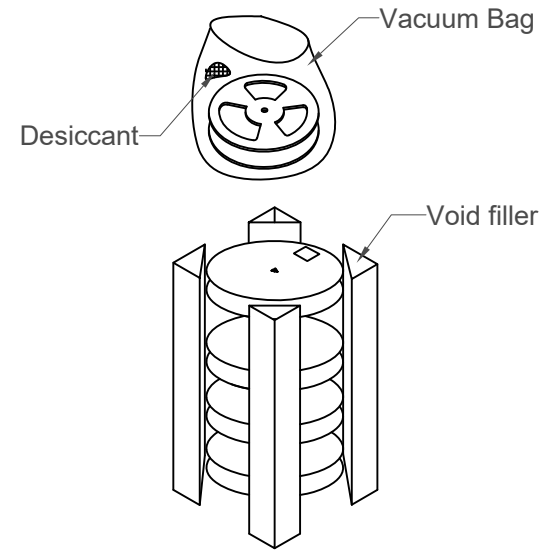

No. of Contacts	W	S	Pcs/Reel	Reel/Carton	Pcs/Carton
4 ~ 19	24	N/A	2000	10	20000
20 ~ 31	32	28.4	2000	8	16000
32 ~ 49,51	44	40.4	2000	6	12000
50, 52 ~ 60	56	52.4	2000	4	8000

Part Number		Product Description			
FFC2B35		FFC/FPC 0.5mm Pitch Side Entry, Bottom Contact, SMT, Height=2.0mm, Front Flip			
Drawing Date		11th June 2021			
By	CC	Tolerances (Except as Noted)		Units:	
Detail	Drawing Release	Length	Angle	Metric (mm)	
Revision	A2	-	-	3rd Angle Projection	
Date	10/01/22				
				This drawing is confidential and copyright of Global Connector Technology, Ltd (GCT). This drawing must not be copied or disclosed without written consent. E & OE	
				GCT www.gct.co	
				Not to Scale	Sheet No. 2/2

1 2 3 4 5 6 7 8