



**HESTORE.HU**

elektronikai alkatrész áruház

**EN:** This Datasheet is presented by the manufacturer.

Please visit our website for pricing and availability at [www.hestore.hu](http://www.hestore.hu).

# 0.8mm Pitch Floating Card Edge Connector

FX27 Series

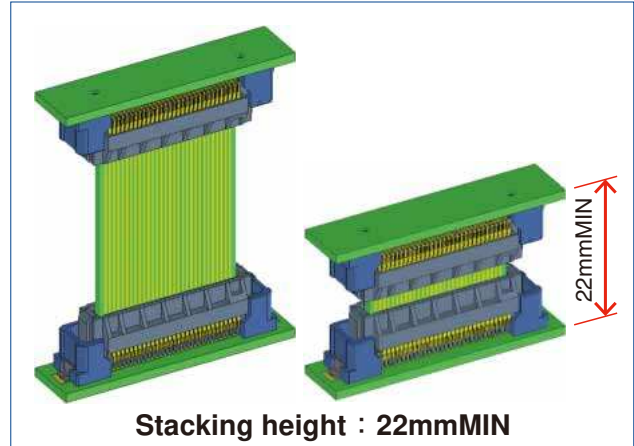
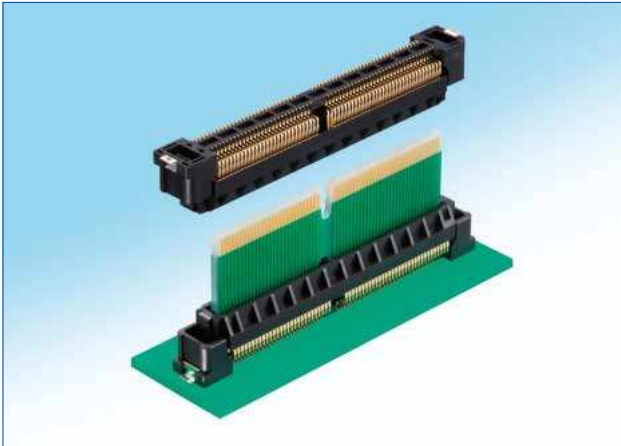

## ■ Features

1. **Contact pitch : 0.8mm**
2. **Stacking Height : 22mm Min.**  
Adjustable height by selecting different PCB interposer heights.
3. **Pin Varieties : 40/60/80/100/120**
4. **Floating Range : 0.6mm Max. in X and Y directions**  
Floating range by using two FX27 connectors is  $\pm 1.2\text{mm}$  max.
5. **High-speed Transmission : 2.5Gbps (PCIe-Gen.1)**
6. **Customizable interposer PCB**
7. **Current capacity : 0.5A/pin**
8. **Pick & Place Mounting (suction tape attached as standard)**
9. **Large guide post for excellent mating performance**  
Easy mating operation due to large self-alignment range.

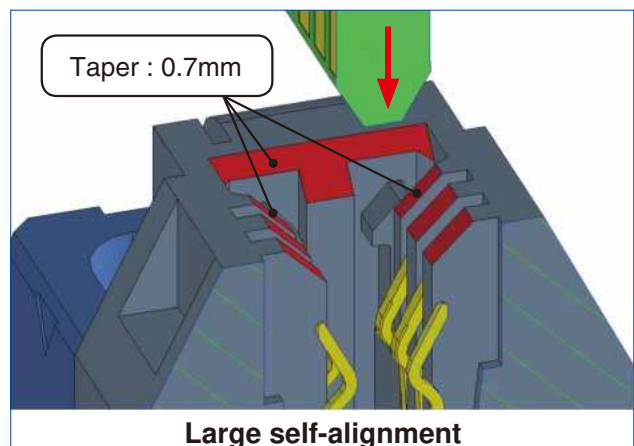
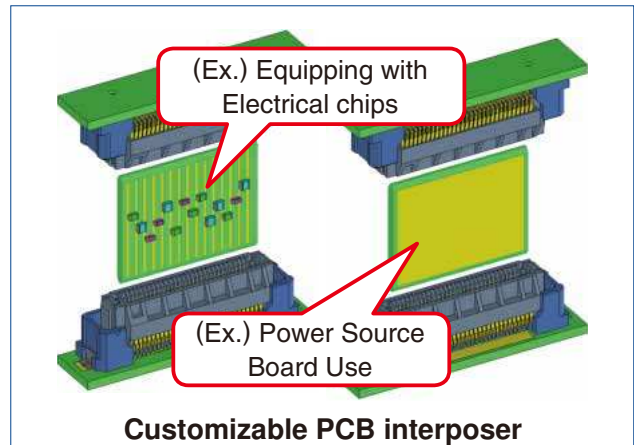
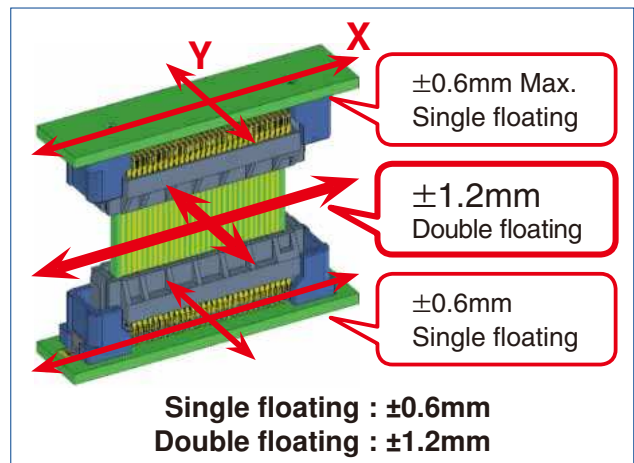

## Product Specifications

Ratings	Rated Current : 0.5A	Operating Temperature : -55 to 105°C (Note 1)
		Storage temperature : -10 to 60°C (Note 2)
	Rated Voltage : 100V AC	Operating/storage humidity range : 85% or less relative humidity (No dew condensation is allowed)

Items	Specifications	Conditions
1. Contact resistance	30mΩ Max. (Note 3)	Measured at 100mA
2. Insulation Resistance	1,000MΩ or more	Measured at 250V DC
3. Withstanding Voltage	No flashover or breakdown	Energized at 300V AC for 1 minute
4. Mating durability	Contact Resistance 40mΩ Max. (Note 3)	100 Insertion/Extraction cycles
5. Vibration proof	No electrical discontinuity of 1μ or more.	Frequency 10-55Hz, half amplitude 0.75mm, 10 cycles in each of the 3-axis directions each for 5 minutes per cycle
6. Shock resistance	No electrical discontinuity of 1μ or more.	Acceleration of 490m/s <sup>2</sup> ; duration 11ms, sine half-wave, 3 cycles in each of the 3 axes each in both directions.
7. Moisture resistance	Contact Resistance 40mΩ max. (Note 3) Insulation Resistance 1,000MΩ max.	Left for 96 hours at 40°C and a humidity of 90 to 95%
8. Temperature cycle	Contact Resistance 40mΩ max. (Note 3) Insulation Resistance 1,000MΩ max.	Temperature -55 → 85°C Time 30 → 30min. for 5 cycles

Note 1 : Includes the temperature rise caused by current flow.

Note 2 : The term storage refers to the long-term storage condition of unused products prior to mounting on PCB.

Note 3 : Contact resistance for 1 connector. Does not include the conductor resistance of the PCB interposer when mated.

## Materials / Finish

Part	Materials	Finish/Remarks	Standard
Insulator	Polyamide resin	Black	UL94V-0
Contact	Copper alloy	Contact part : gold plating Mounting part : gold plating	-
Solder tab	Brass	Reflow tin plating	-

## Product Number Structure

Refer to the chart below when determining the product specifications from the product number.  
Please select from the product numbers listed in this catalog when placing orders.

### Straight receptacle

**FX27 - 120 S - 0.8 SV**

①      ②      ③      ④      ⑤

① Series Name	: FX27
② No. of pos.	
③ Connector type	S : Receptacle type
④ Contact pitch	: 0.8mm
⑤ Product type	SV : Straight type

## High-speed transmission property

### Pin assignment

The following pin arrangement is recommended to match the 100Ω differential impedance and to contain cross-talk.

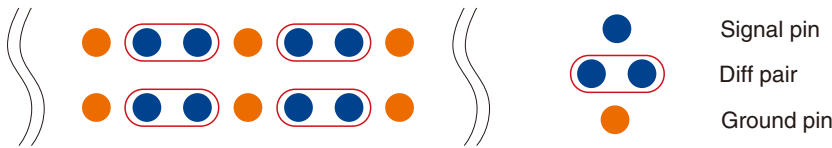

### Insertion Loss

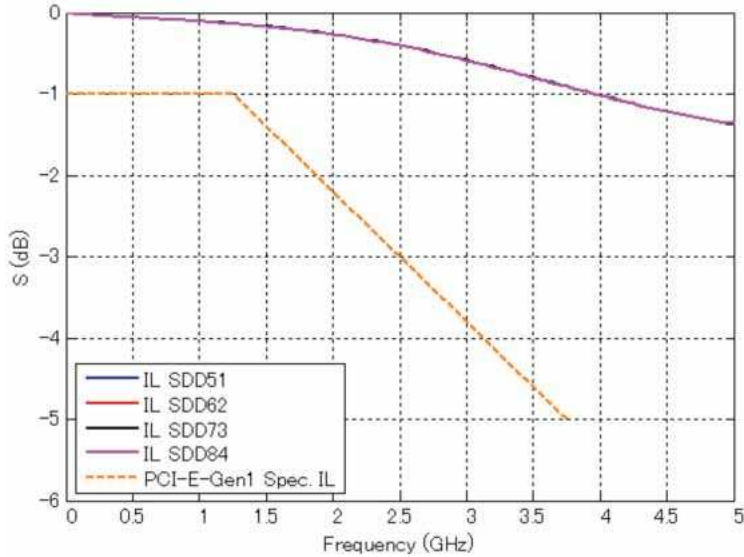

### Intra-pair skew

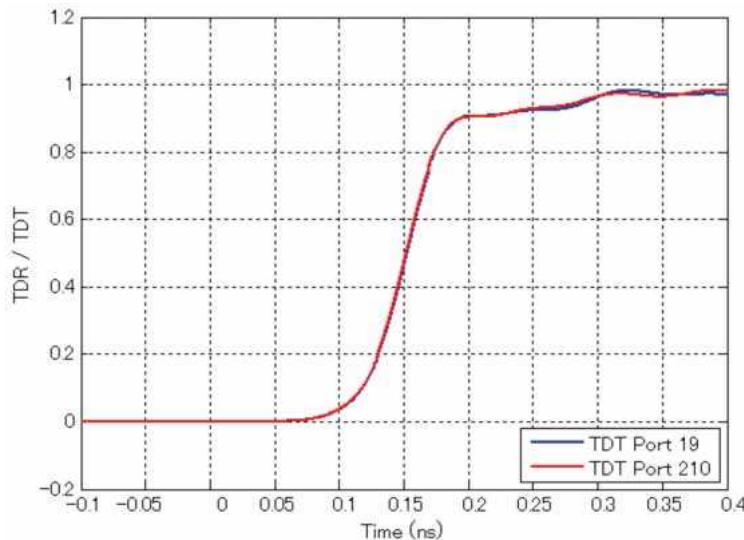

Nov 2022 Copyright 2022 HORSE ELECTRIC CO., LTD. All Rights Reserved

Return loss

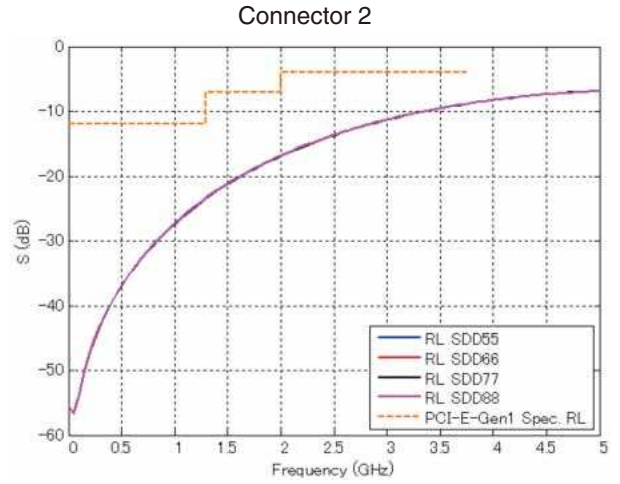
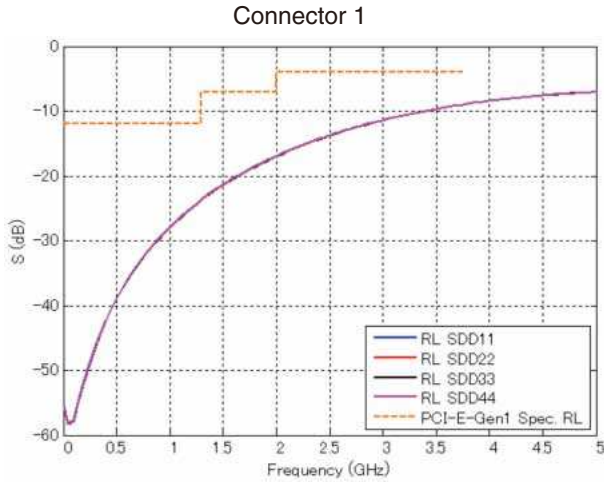

Near End Cross-Talk (NEXT)

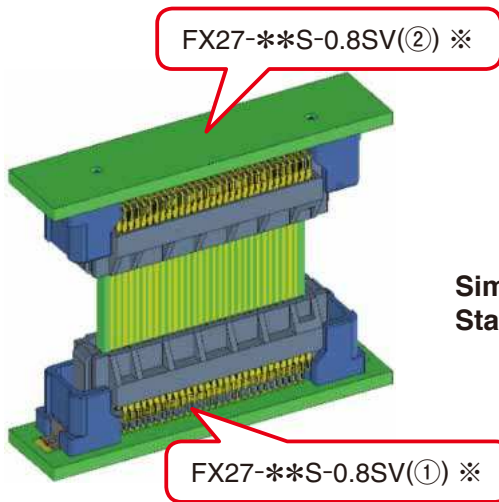
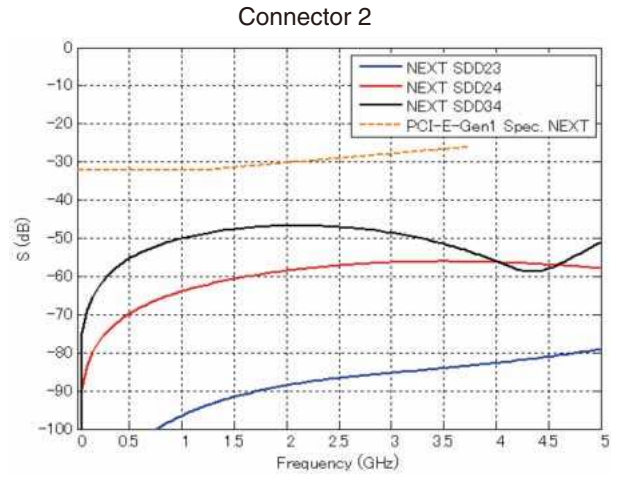
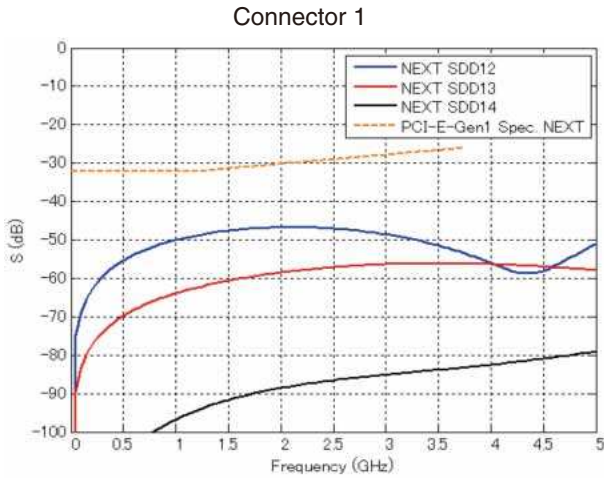

Simulation Tool : HFSS Ver.2016.1.0  
Standard Impedance : 100Ω

\*Simulation performed using the same FX27 connector for connector 1 and connector 2

## Floating Range

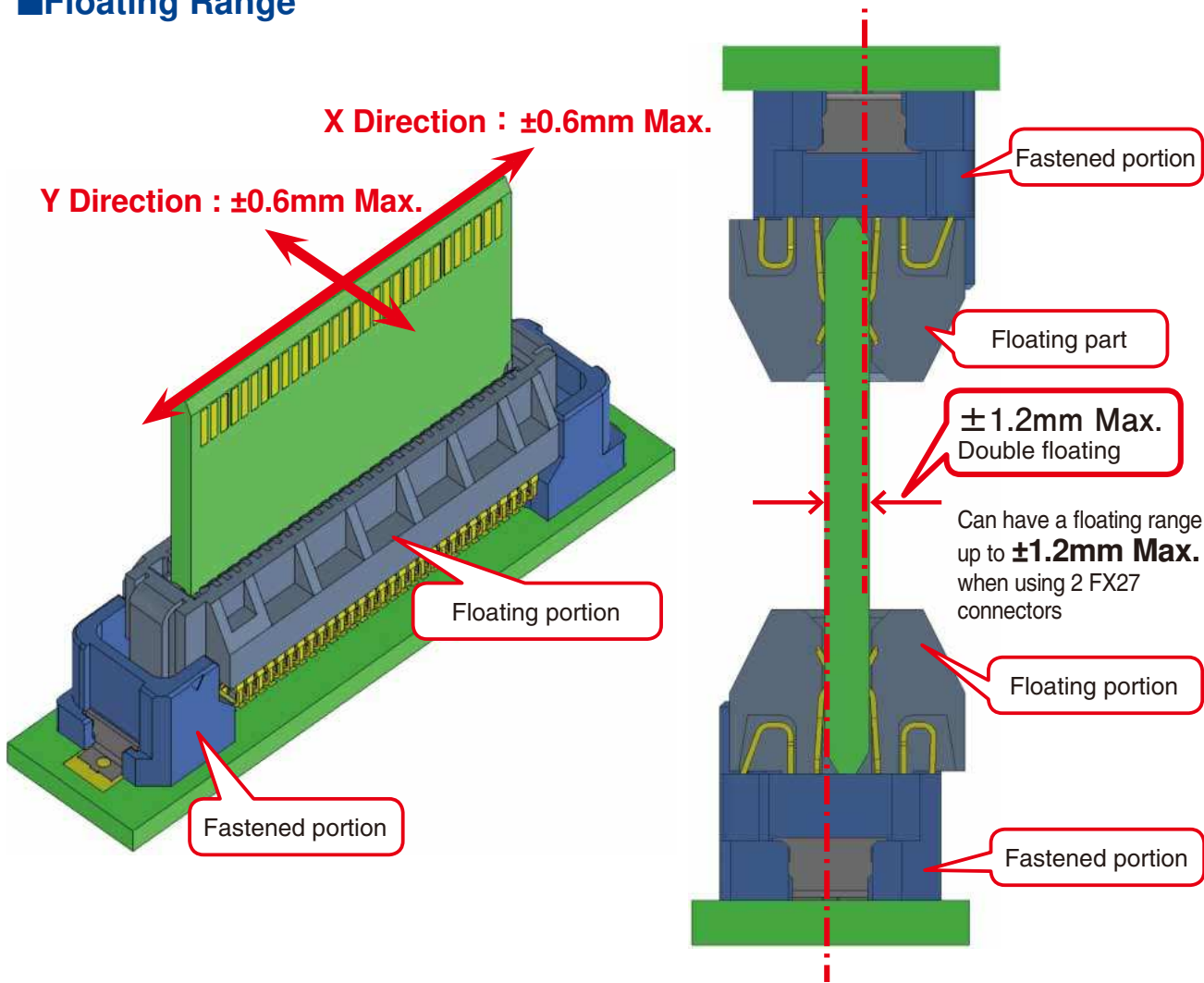

## Number of contacts variations

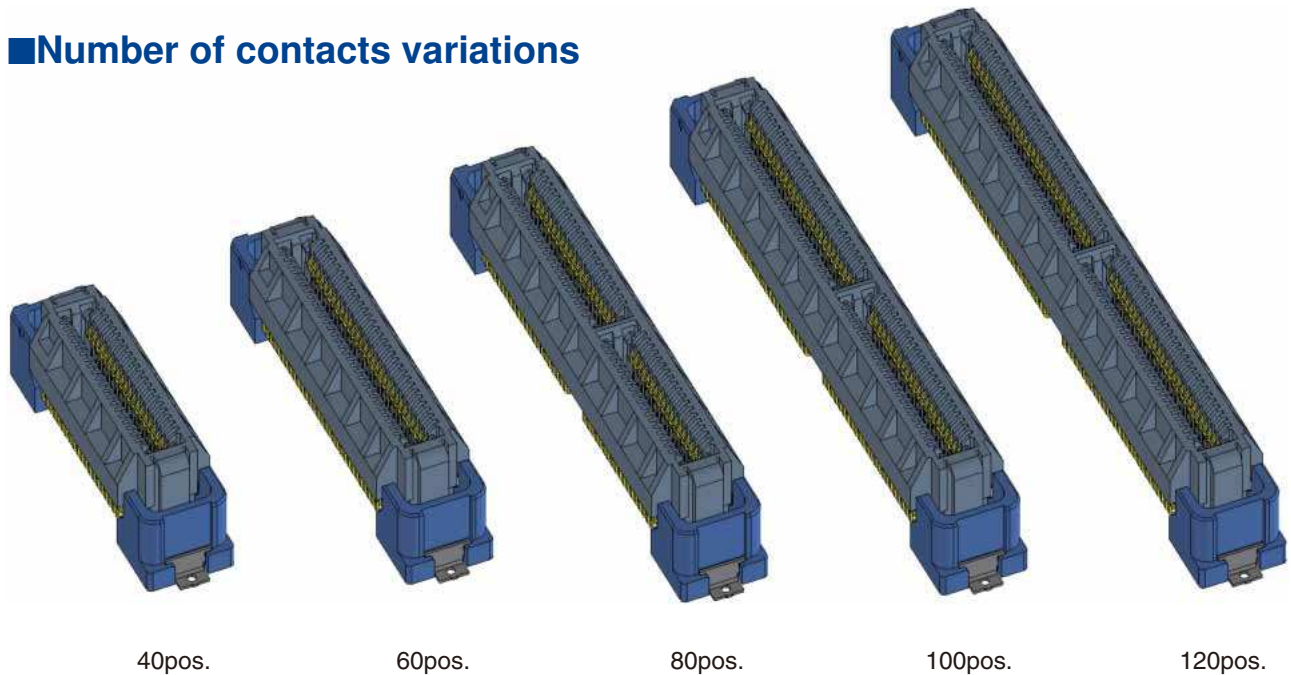

Nov 2022 Copyright 2022 Hirose Electric Co., Ltd. All Rights Reserved

## Product Dimensions

### ● Straight Receptacle

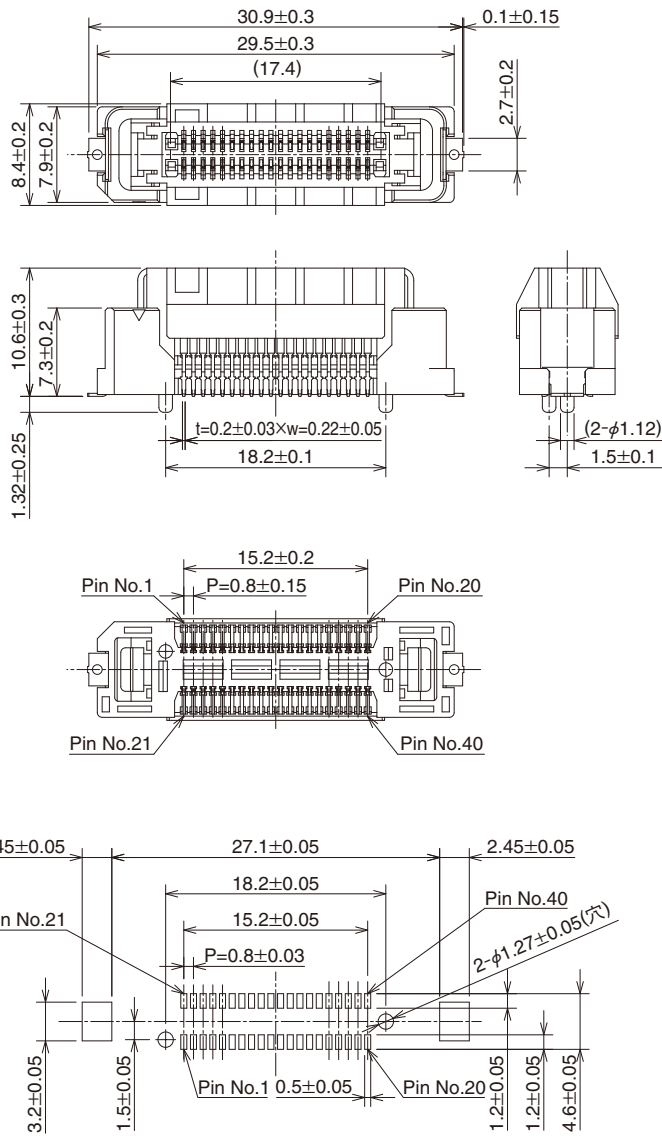
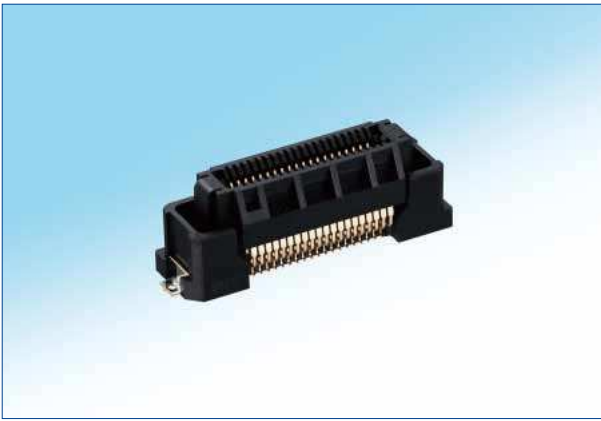

Part No.	HRS No.	No. of contacts	Packaging Quantity
FX27-40S-0.8SV	577-1002-0 00	40	300/RL

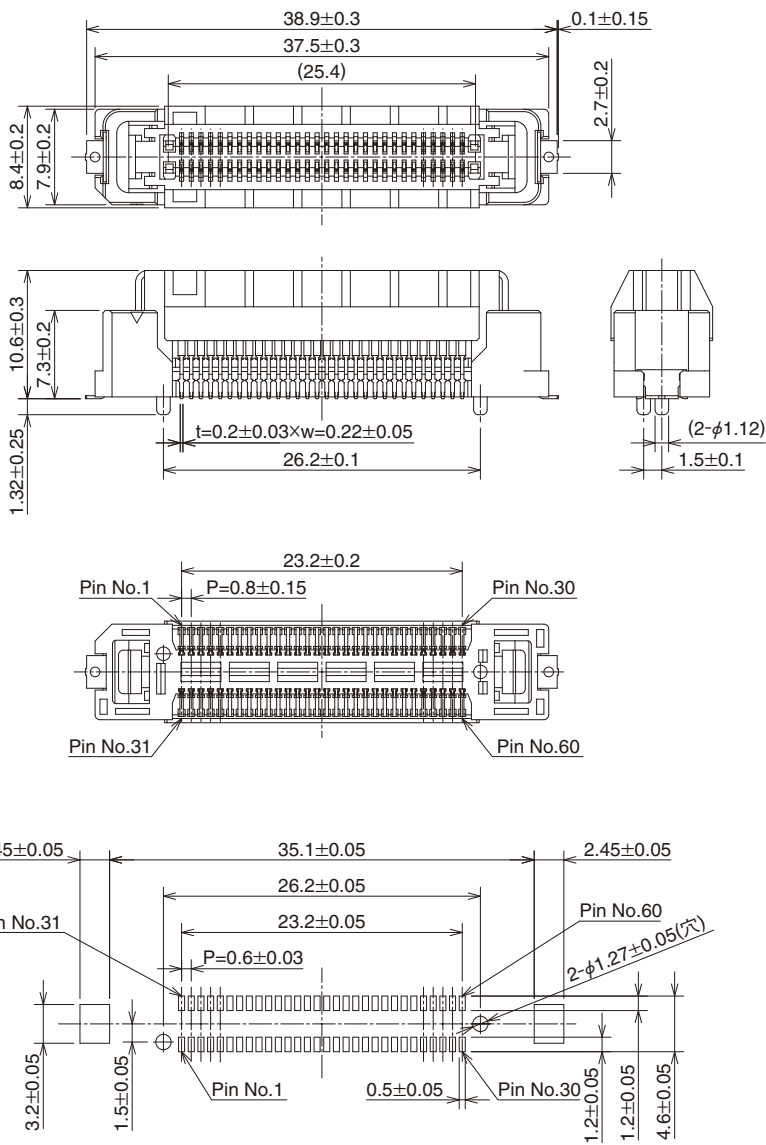

Part No.	HRS No.	No. of contacts	Packaging Quantity
FX27-60S-0.8SV	577-1003-0 00	60	300/RL



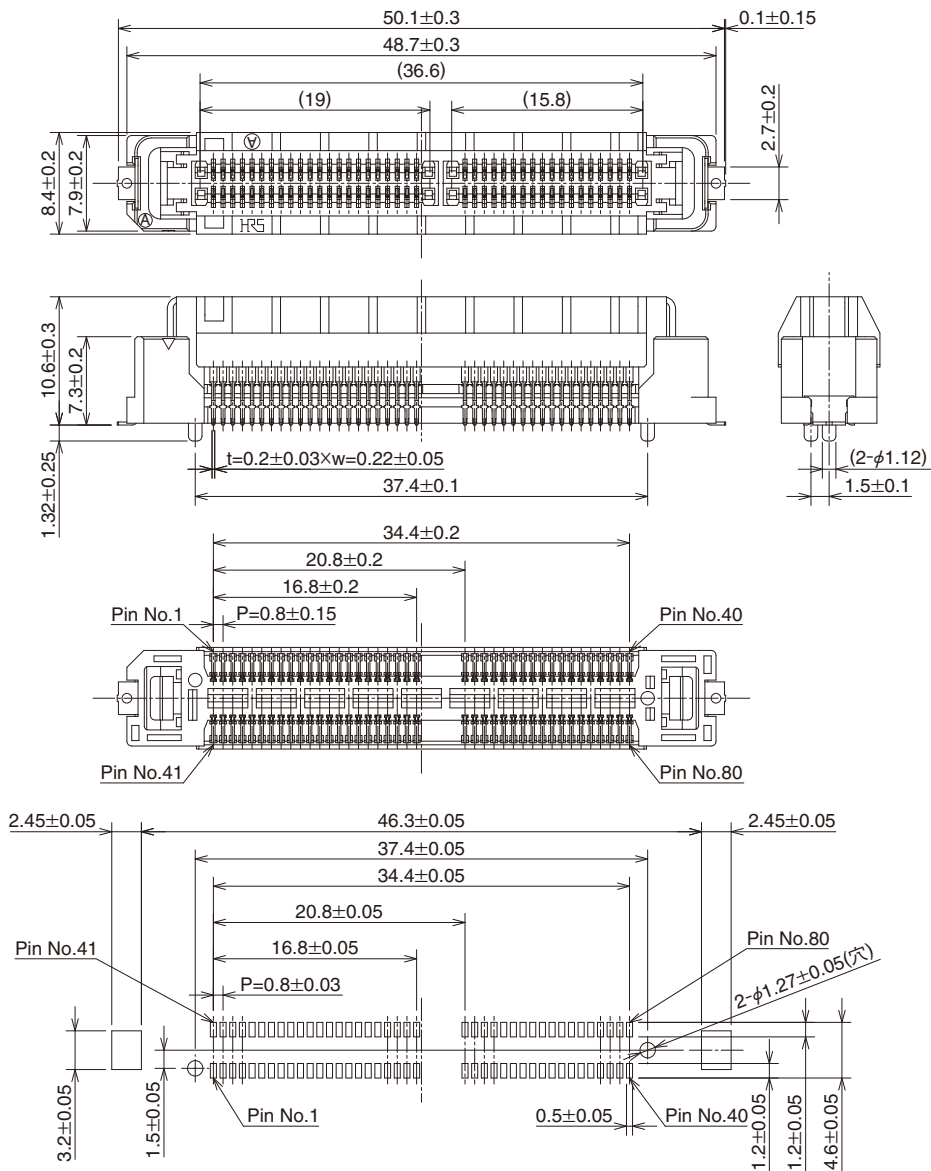
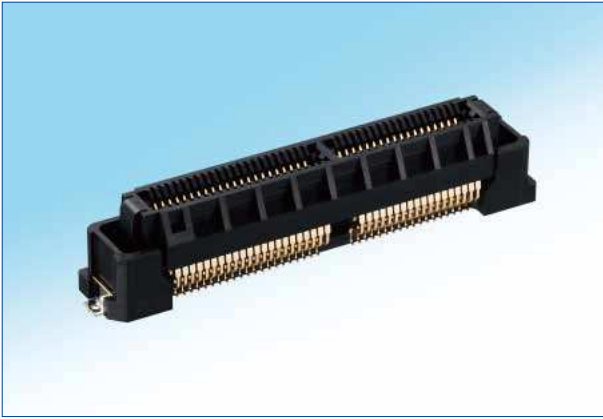

Part No.	HRS No.	No. of contacts	Packaging Quantity
FX27-80S-0.8SV	577-1004-0 00	80	300/RL

Nov 2022 Copyright 2022 Hirose Electric Co., Ltd. All Rights Reserved

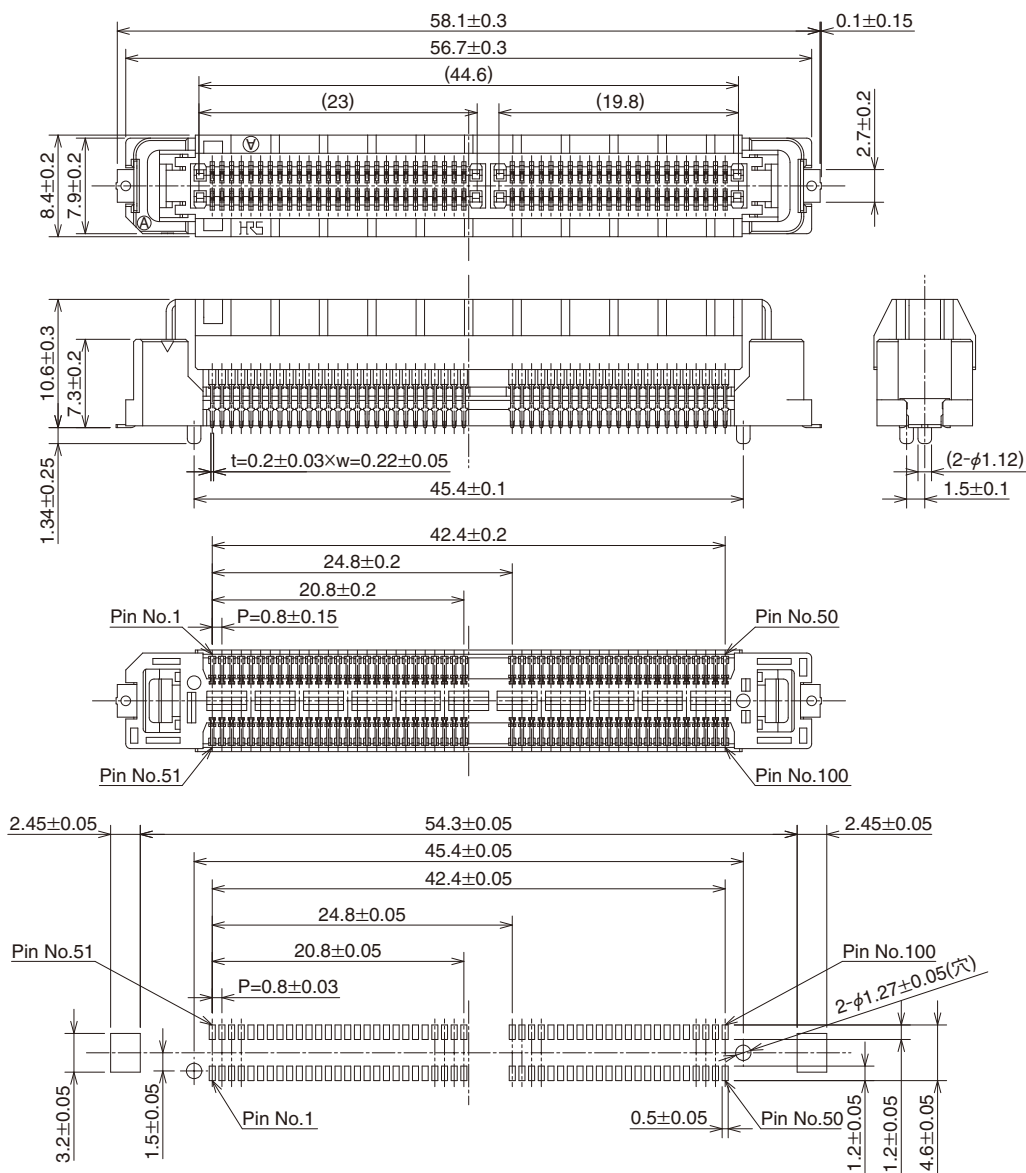
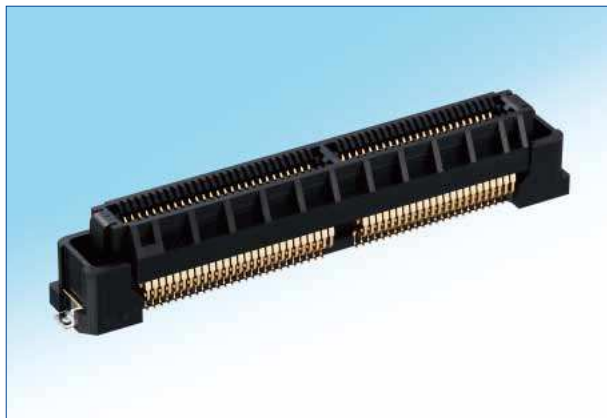

Part No.	HRS No.	No. of contacts	Packaging Quantity
FX27-100S-0.8SV	577-1005-0 00	100	150/RL

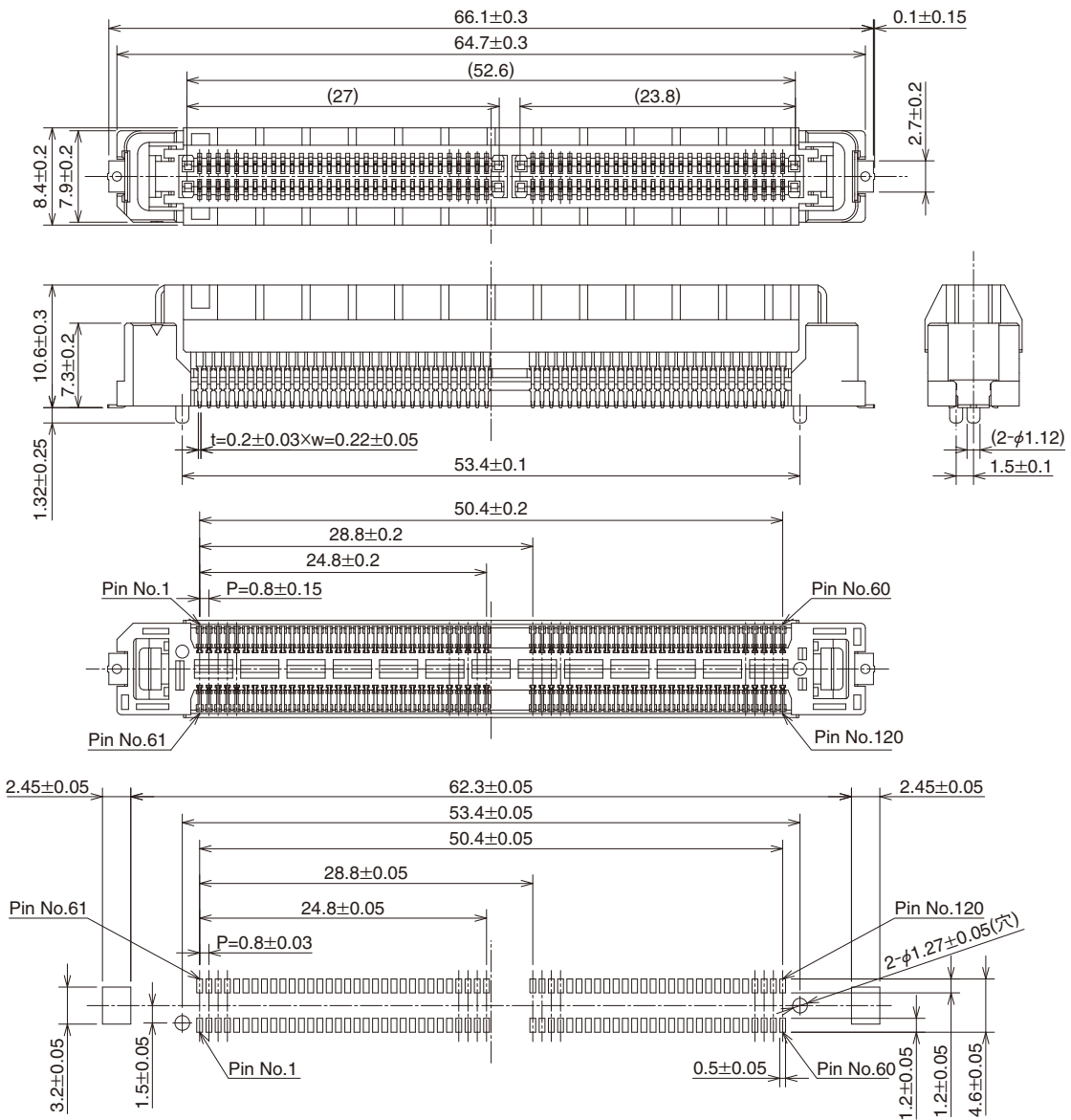
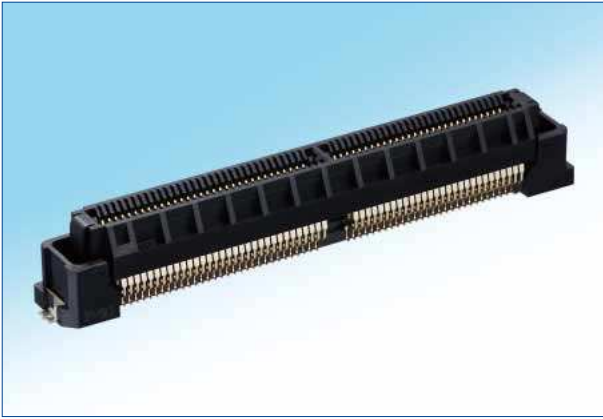

Part No.	HRS No.	No. of contacts	Packaging Quantity
FX27-120S-0.8SV	577-1001-0 00	120	150/RL

## Embossed Packaging Diagram

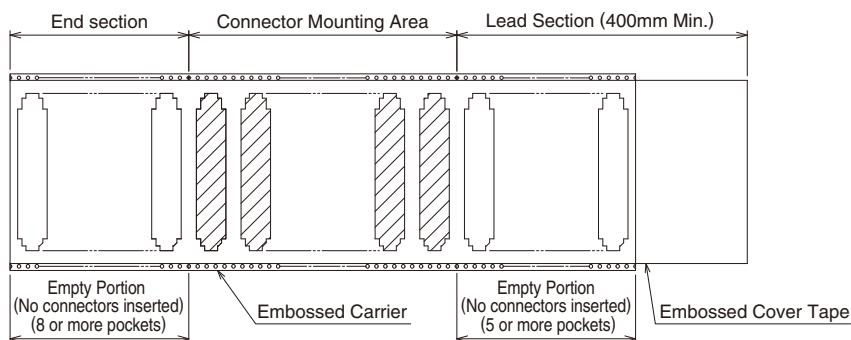
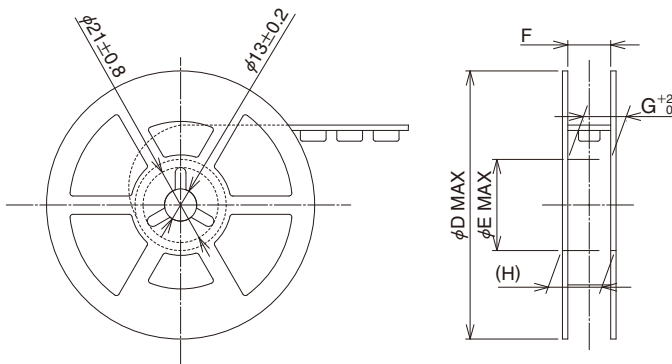
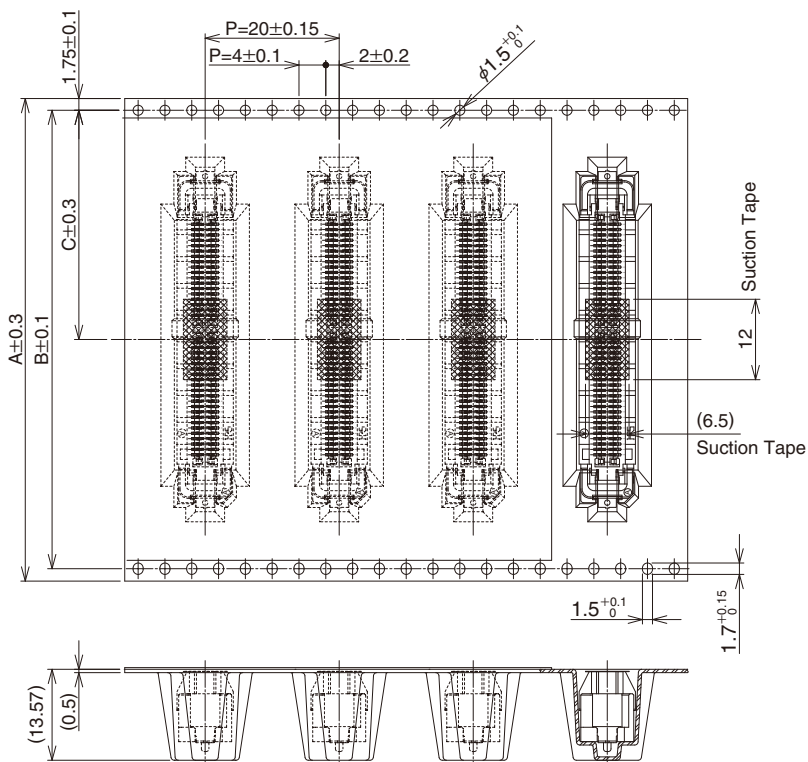

Unit : mm

Part No.	A	B	C	D	E	F	G	H
FX27-40S-0.8SV	56	52.4	26.2	382	102	55.9~59.4	56.4	62.4
FX27-60S-0.8SV	72	68.4	34.2	382	102	71.9~75.4	72.4	78.4
FX27-80S-0.8SV	72	68.4	34.2	382	102	71.9~75.4	72.4	78.4
FX27-100S-0.8SV	88	84.4	42.2	332	152	87.9~91.4	88.4	94.4
FX27-120S-0.8SV	88	84.4	42.2	332	152	87.9~91.4	88.4	94.4

Nov 2022 Copyright 2022 Hirose Electric Co., Ltd. All Rights Reserved

## Recommended PCB Interposer Dimensions

CL indicates the center of 17.25 **40S**

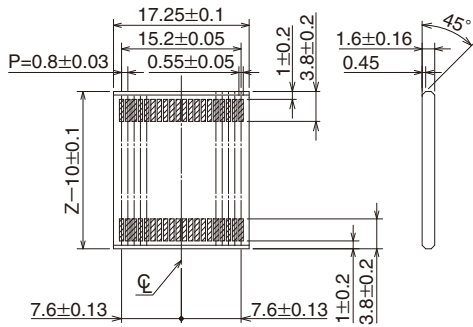

CL indicates the center of 25.25 **60S**

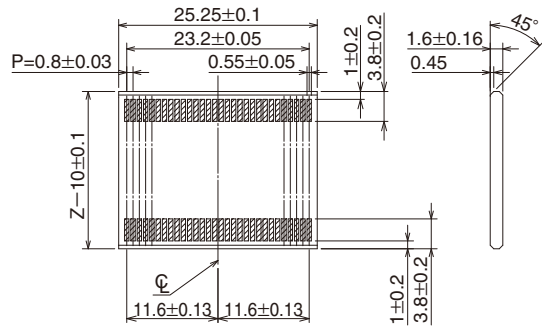

CL indicates the center of 36.45 **80S**

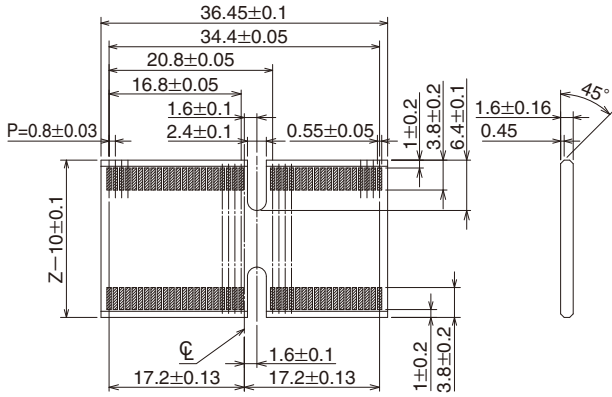

CL indicates the center of 44.45 **100S**

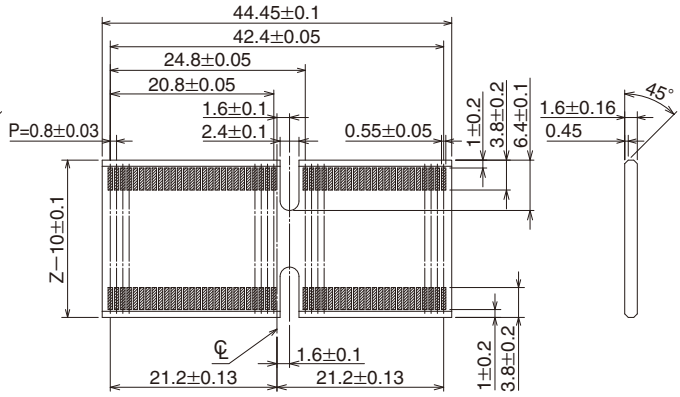

CL indicates the center of 52.45 **120S**

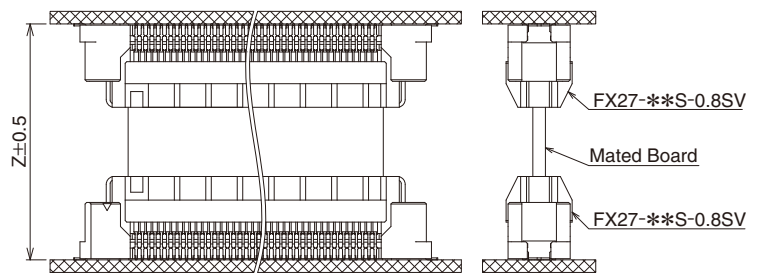
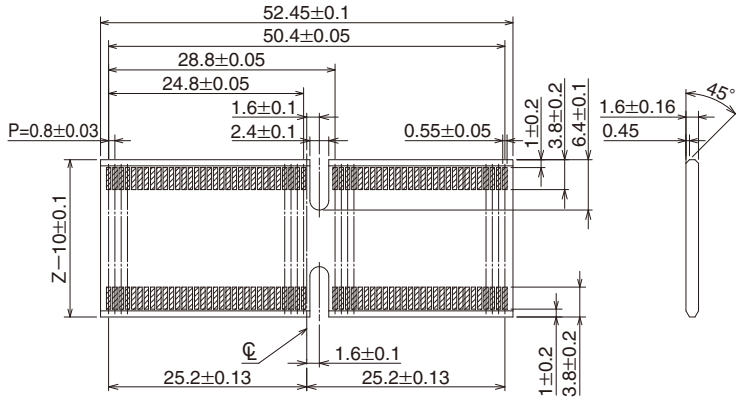

Customer supplied PCB interposer.

Nov 2022 Copyright 2022 HORSE ELECTRIC CO., LTD. All Rights Reserved

## ◆ Recommended Temperature Profile

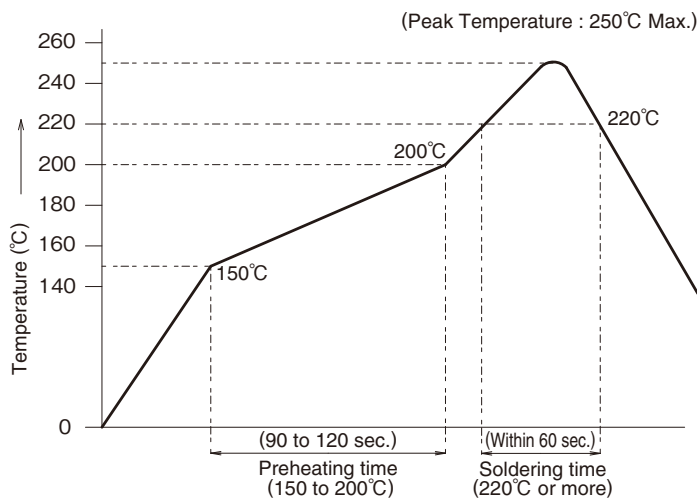

<Applicable conditions>

- Test PCB Dimensions : 110×60×1.6mm
- Material : Glass epoxy
- Solder composition : Sn-3Ag-0.5Cu
- Flux content : 11wt%
- Metal mask thickness : 0.12mm, 0.15mm
- Number of reflow times : 2 times max.

\*The temperature profile is a reference under the condition of the above settings : Temperature profile may change depending on the conditions such as solder paste types, manufacturers, PCB size, and other soldering materials. We confirmed there is no issue on the 2nd reverse mounting, but please use after thoroughly confirming the mounting state.

## ◆ Cleaning Conditions

### ● Cleaning with organic solvent

Solvent	Normal Temperature Cleaning	Heated cleaning
IPA (Isopropyl alcohol)	○	○

### ● Cleaning with water

When water-type cleaning agents (terpene, alkaline saponification agents) are used, select cleaning agents based on the 'table of influence' on metals and resins issued by the cleaning agent manufacturer.  
 Caution : Do not leave with any water content left.

### ● Cleaning Precautions

When cleaning the parts with organic solvents and water-type agents, if flux or cleaning agents remain in the connector, it could cause the deterioration of electric performance.  
 Please be sure to check if adequate cleaning has been completed.

## ◆ Usage Precautions

### ● Pin Assignment

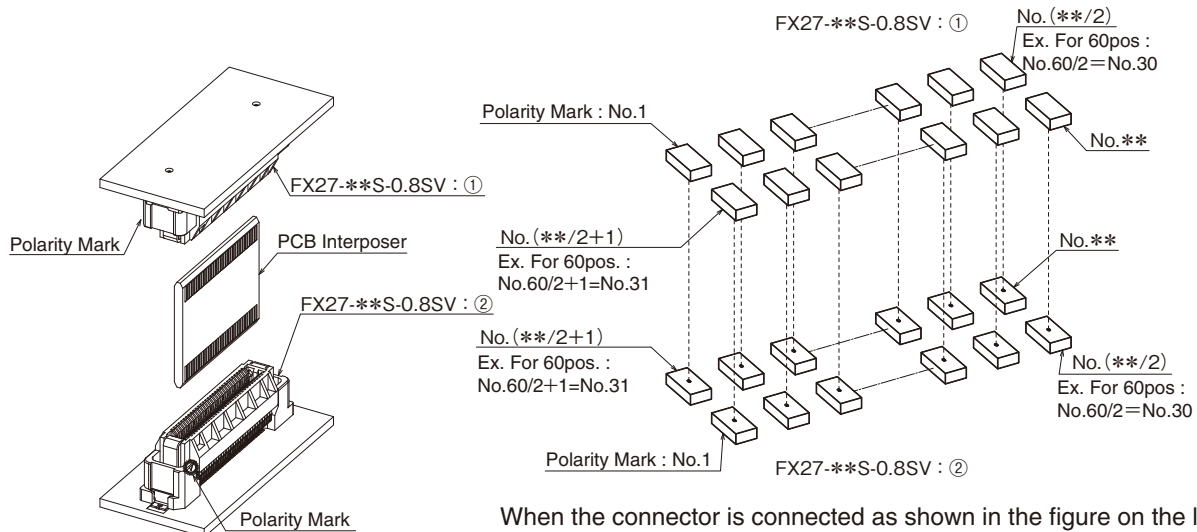

When the connector is connected as shown in the figure on the left, polarity marks 1 and 2 of the FX27-\*\*\*S-0.8SV are inverted. Please pay attention to board circuit pin assignment.

### ●Securing Boards

Using only connectors is not recommended. The board is designed to be secured with a spacer.  
 If the board is supported only by the connector, an excessive load may be applied to the connector which may result in damage or contact failure.  
 Take measures to secure the board other than using the connector.

### ●Mating Precautions

·The self-alignment range is  $\pm 0.7\text{mm}$  in the X and Y directions.  
 Insert the connector straight in without applying excessive load during mating.

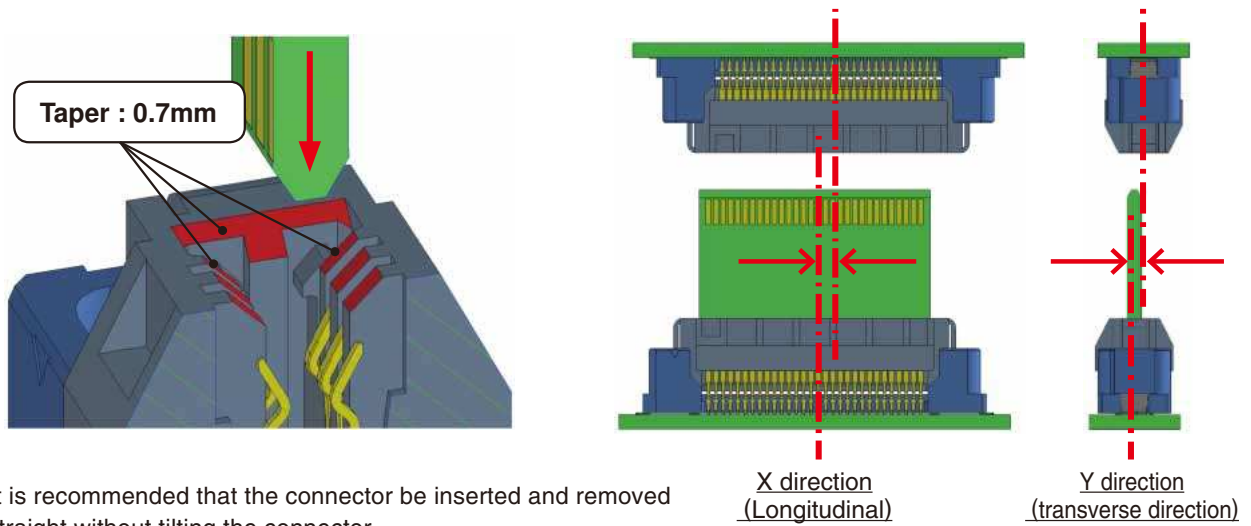

·It is recommended that the connector be inserted and removed straight without tilting the connector.

### ●Misalignment allowance in Mated Condition (Floating Amount)

Since this connector has a floating structure, the maximum allowable PCB misalignment amount is  $\pm 0.6\text{mm}$  in the X and Y directions when mated.  
 When two FX27 connectors are used for stacking connections, they have a double floating capability, allowing for a maximum PCB misalignment of  $\pm 0.12\text{mm}$  in the X and Y directions.  
 However, this product cannot be used to absorb misalignment when there are constant changes due to vibration, etc.  
 Be sure to secure the boards after mating.  
 The floating operation can be repeated 100 times max. based on the connector durability (insertion/extraction times).

### ◆Supplementary

#### ●Friction Lock during Initial Insertion/Extraction

Ex. FX27-60S-0.8SV

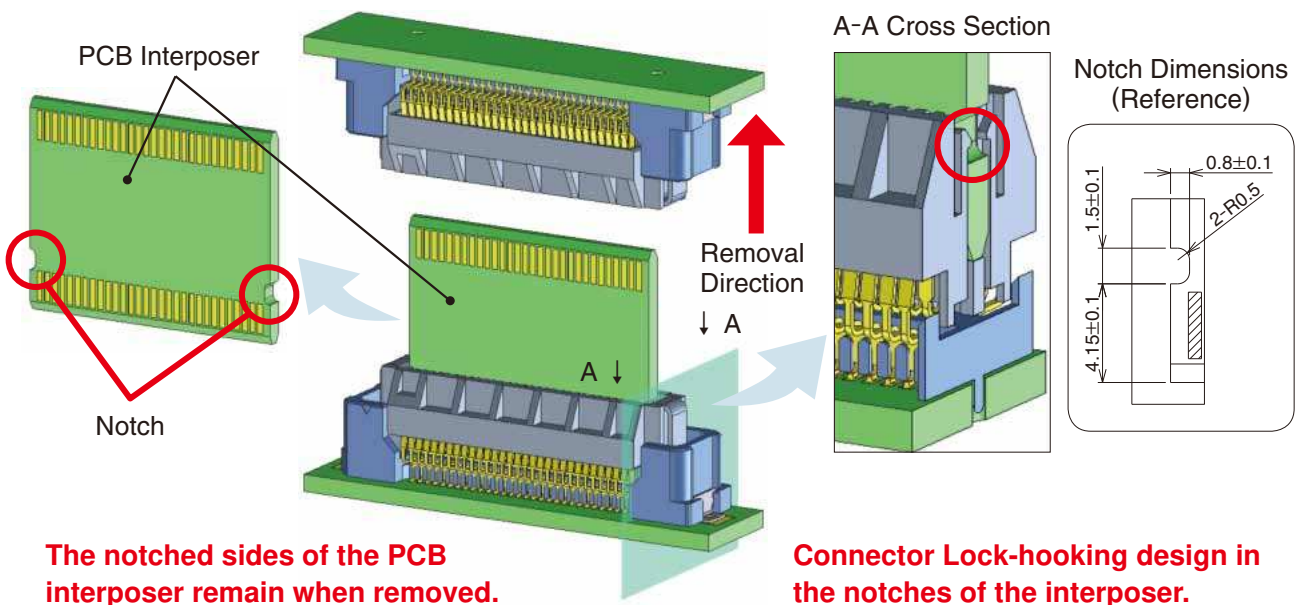

The notched sides of the PCB interposer remain when removed.

Connector Lock-hooking design in the notches of the interposer.

Nov 2022 Copyright 2022 HORSE ELECTRIC CO., LTD. All Rights Reserved.

MEMO :

Area with horizontal dashed lines for notes.



**USA:**

**HIROSE ELECTRIC (U.S.A.), INC. HEADQUARTERS CHICAGO OFFICE**  
 2300 Warrenville Road, Suite 150,  
 Downers Grove, IL 60515  
 Phone : +1-630-282-6700  
<http://www.hirose.com/us/>

**USA:**

**HIROSE ELECTRIC (U.S.A.), INC. SAN JOSE OFFICE**  
 2841 Junction Ave, Suite 200  
 San Jose, CA. 95134  
 Phone : +1-408-253-9640  
 Fax : +1-408-253-9641  
<http://www.hirose.com/us/>

**USA:**

**HIROSE ELECTRIC (U.S.A.), INC. DETROIT OFFICE (AUTOMOTIVE)**  
 17197 N. Laurel Park Drive, Suite 253,  
 Livonia, MI 48152  
 Phone : +1-734-542-9963  
 Fax : +1-734-542-9964  
<http://www.hirose.com/us/>

**USA:**

**HIROSE ELECTRIC (U.S.A.), INC. BOSTON OFFICE**  
 300 Brickstone Square Suite 201,  
 Andover, MA 01810  
 Phone : +1-978-662-5255

**THE NETHERLANDS:**

**HIROSE ELECTRIC EUROPE B.V.**  
 Hogehillweg #8 1101 CC Amsterdam Z-0  
 Phone : +31-20-6557460  
 Fax : +31-20-6557469  
<http://www.hirose.com/eu/>

**GERMANY:**

**HIROSE ELECTRIC EUROPE B.V. GERMAN BRANCH**  
 Schoenbergstr. 20, 73760 ostfildern  
 Phone : +49-711-456002-1  
 Fax : +49-711-456002-299  
<http://www.hirose.com/eu/>

**GERMANY:**

**HIROSE ELECTRIC EUROPE B.V. NUREMBERG OFFICE**  
 Neumeyerstrasse 22-26, 90411 Nurnberg  
 Phone : +49-911 32 68 89 63  
 Fax : +49-911 32 68 89 69  
<http://www.hirose.com/eu/>

**GERMANY:**

**HIROSE ELECTRIC EUROPE B.V. HANOVER OFFICE**  
 Bayernstr. 3, Haus C 30855 Langenhagen, Germany  
 Phone : +49-511 97 82 61 30  
 Fax : +49-511 97 82 61 35  
<http://www.hirose.com/eu/>

**FRANCE:**

**HIROSE ELECTRIC EUROPE B.V. PARIS OFFICE**  
 130 Avenue Joseph Kessel, Bat E, 78960  
 Voisins le Bretonneux, France  
 Phone : +33-1-85764886  
 Fax : +33-1-85764823  
<http://www.hirose.com/eu/>

**UNITED KINGDOM:**

**HIROSE ELECTRIC EUROPE BV (UK BRANCH)**  
 4 Newton Court, Kelvin Drive, Knowlhill,  
 Milton Keynes, MK5 8NH  
 Phone : +44-1908 202050  
 Fax : +44-1908 202058  
<http://www.hirose.com/eu/>

**CHINA:**

**HIROSE ELECTRIC (CHINA) CO., LTD. (SHANGHAI, HEADQUARTERS)**  
 18, Enterprise Center Tower 2, 209# Gong He  
 Road, Jing'an District, Shanghai, CHINA 200070  
 Phone : +86-21-6391-3355  
 Fax : +86-21-6391-3335  
<http://www.hirose.com/cn/>

**CHINA:**

**HIROSE ELECTRIC (CHINA) CO.,LTD. BEIJING BRANCH**  
 A1001, Ocean International Center, Building 56# East 4th  
 Ring Middle Road, ChaoYang District, Beijing, 100025  
 Phone : +86-10-5165-9332  
 Fax : +86-10-5908-1381  
<http://www.hirose.com/cn/>

**CHINA:**

**HIROSE ELECTRIC (CHINA) CO., LTD. SHENZHEN BRANCH**  
 Room 09-13, 19/F, Office Tower Shun Hing Square, Di Wang Commercial Centre,  
 5002 Shen Nan Dong Road, Shenzhen City, Guangdong Province, 518008  
 Phone : +86-755-8207-0851  
 Fax : +86-755-8207-0873  
<http://www.hirose.com/cn/>

**HONG KONG:**

**HIROSE ELECTRIC HONGKONG TRADING CO., LTD.**  
 Room 1001, West Wing, Tsim Sha Tsui Centre, 66  
 Mody Road, Tsim Sha Tsui East, Kowloon, Hong Kong  
 Phone : +852-2803-5338  
 Fax : +852-2591-6560  
<http://www.hirose.com/hk/>

**TAIWAN:**

**HIROSE ELECTRIC TAIWAN CO., LTD.**  
 103 8F, No.87, Zhengzhou Rd., Taipei  
 Phone : +886-2-2555-7377  
 Fax : +886-2-2555-7355  
<http://www.hirose.com/tw/>

**KOREA:**

**HIROSE KOREA CO.,LTD.**  
 143, Gongdan 1-daero, Siheung-si,  
 Gyeonggi-do, 15084, Korea  
 Phone : +82-31-496-7000  
 Fax : +82-31-496-7100  
<http://www.hirose.co.kr/>

**SINGAPORE:**

**HIROSE ELECTRIC SINGAPORE PTE. LTD.**  
 03, Anson Road, #20-01, Springleaf Tower,  
 Singapore 079909  
 Phone : +65-6324-6113  
 Fax : +65-6324-6123  
<http://www.hirose.com/sg/>

**INDIA:**

**HIROSE ELECTRIC SINGAPORE PTE. LTD. DELHI LIAISON OFFICE**  
 Office NO.552, Regus-Green Boulevard, Level5, Tower C,  
 Sec62, Plot B-9A, Block B, Noida, 201301, Uttar Pradesh, India  
 Phone : +91-12-660-8018  
 Fax : +91-120-4804949  
<http://www.hirose.com/sg/>

**INDIA:**

**HIROSE ELECTRIC SINGAPORE PTE. LTD. BANGALORE LIAISON OFFICE**  
 Unit No-403, 4th Floor, No-84, Barton Centre, Mahatma  
 Gandhi (MG) Road, Bangalore 560 001, Karnataka, India  
 Phone : +91-80-4120 1907  
 Fax : +91-80-4120 9908  
<http://www.hirose.com/sg/>

**MALAYSIA:**

**PENANG REPRESENTATIVE OFFICE**  
 73-3-1, Ideal@The One, Jalan Mahsuri, Bayan  
 Lepas Penang, 11950, Malaysia  
 Phone : +604-648-5536  
<http://www.hirose.com/sg/>

**THAILAND:**

**BANGKOK OFFICE (REPRESENTATIVE OFFICE)**  
 Unit 4703, 47th FL., 1 Empire Tower, South Sathorn  
 Road, Yannawa, Sathorn, Bangkok 10120 Thailand  
 Phone : +66-2-686-1255  
 Fax : +66-2-686-3433  
<http://www.hirose.com/sg/>



**HIROSE ELECTRIC CO.,LTD.**

2-6-3,Nakagawa Chuoh,Tsuzuki-Ku,Yokohama-Shi 224-8540,JAPAN  
 TEL: +81-45-620-3526 Fax: +81-45-591-3726  
<http://www.hirose.com>  
<http://www.hirose-connectors.com>