



**HESTORE.HU**

elektronikai alkatrész áruház

**EN:** This Datasheet is presented by the manufacturer.

Please visit our website for pricing and availability at [www.hestore.hu](http://www.hestore.hu).

**DISPLAY Elektronik GmbH**

**DATA SHEET**

**LCD MODULE**

**DEM 40491 SYH-LY**

*Product Specification*

*Version : 4.1.1*

**24/May/2008**

# GENERAL SPECIFICATION

---

MODULE NO. :

## DEM 40491 SYH-LY

CUSTOMER P/N

VERSION NO.	CHANGE DESCRIPTION	DATE
0	ORIGINAL VERSION	08.02.2001
1	CHANGE FUNCTION	22.02.2001
2	CHANGE PIN ASSIGNMENT	26.02.2001
3	CHANGE DDRAM	27.02.2001
4	ADD A/K CONTACT HOLES	29.03.2001
4.1.1	CHANGE IC	24.05.2008

PREPARED BY: CC

DATE: 24.05.2008

APPROVED BY: MH

DATE: 24.05.2008

**CONTENTS**

**1. FUNCTIONS & FEATURES .....4**

**2. MECHANICAL SPECIFICATIONS.....4**

**3. BLOCK DIAGRAM.....5**

**4. EXTERNAL DIMENSIONS.....5**

**6. PCB DRAWING AND DESCRIPTION .....7**

**7. BACKLIGHT & CHARACTERISTICS (TA=-20~+70°C) .....8**

**8. DISPLAY DATA RAM (DDRAM) .....9**

**9. MAXIMUM ABSOLUTE LIMIT .....9**

**10. ELECTRICAL CHARACTERISTICS .....10**

**11.CONTROL AND DISPLAY COMMAND .....12**

**12. STANDARD CHARACTER PATTERN .....13**

**13. LCD MODULES HANDLING PRECAUTIONS.....14**

**14. OTHERS.....14**

**1. FUNCTIONS & FEATURES**

MODULE NAME	LCD TYPE
DEM 40491 SYH-LY	STN Yellow-Green Transflective Positive mode

- Viewing Direction : 6 o'clock
- Driving Scheme : 1/16 Duty Cycle, 1/5 Bias
- Power Supply Voltage : 5.0 Volt (typ.)
- Backlight : LED, Yellow-Green, Lightbox
- V<sub>LCD</sub> Adjustable for Best Contrast : LCD Drive Voltage:4.5 Volt (typ.)
- Display Format : 40 x 4 Characters (5x8 dots, Format : 208 Kinds)
- Internal Memory : CGROM (10,080 bits )  
: CGRAM (64x8 bits )  
: DDRAM (80x8 bits for 80 Digits)
- Interface : Easy Interface with a 4-bit or 8-bit MPU
- Operating Temperature : -20°C ~ 70°C
- Storage Temperature : -30°C ~ 80 °C

**2. MECHANICAL SPECIFICATIONS**

- Module Size : 190.00 x 54.00 x 14.00 mm
- Character Pitch : 3.53 x 6.09 mm
- Character Size : 2.78 x 4.89 mm
- Character Font : 5 x 8 dots
- Dot Size : 0.50 x 0.55 mm
- Dot Pitch : 0.57 x 0.62 mm

3. BLOCK DIAGRAM

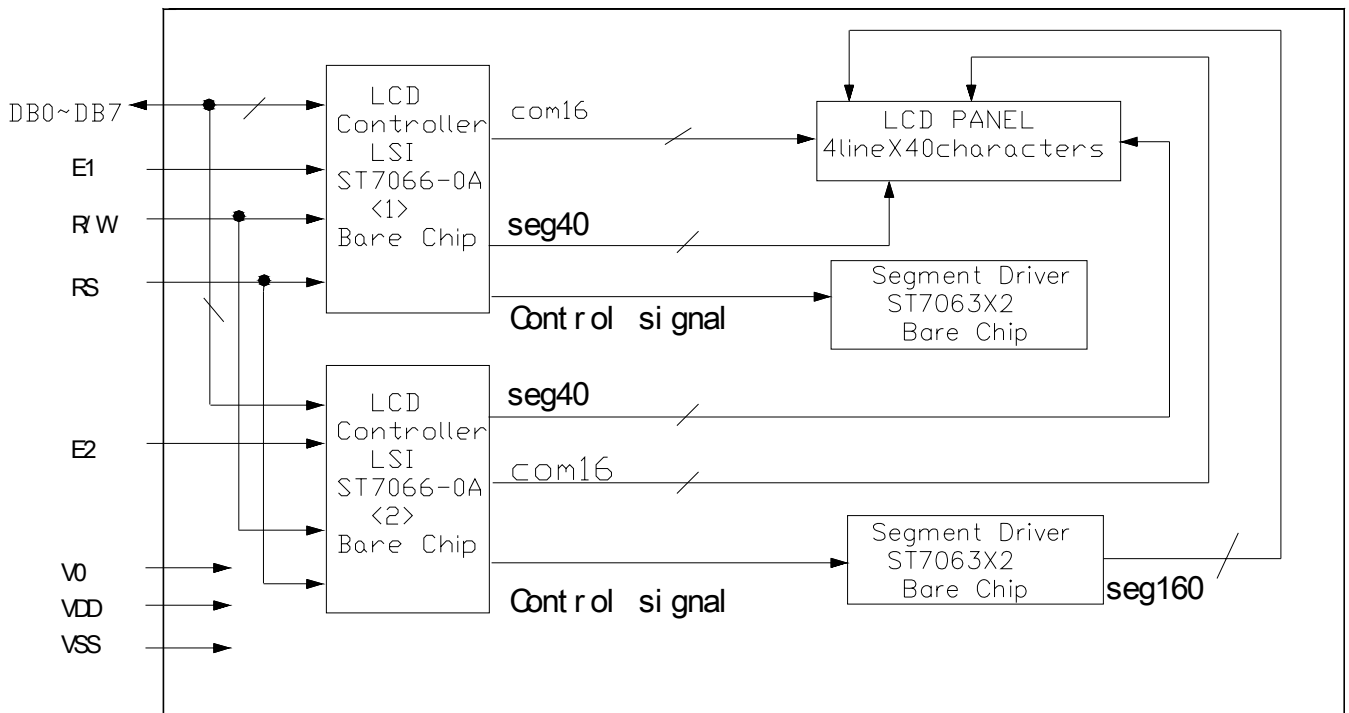

4. EXTERNAL DIMENSIONS

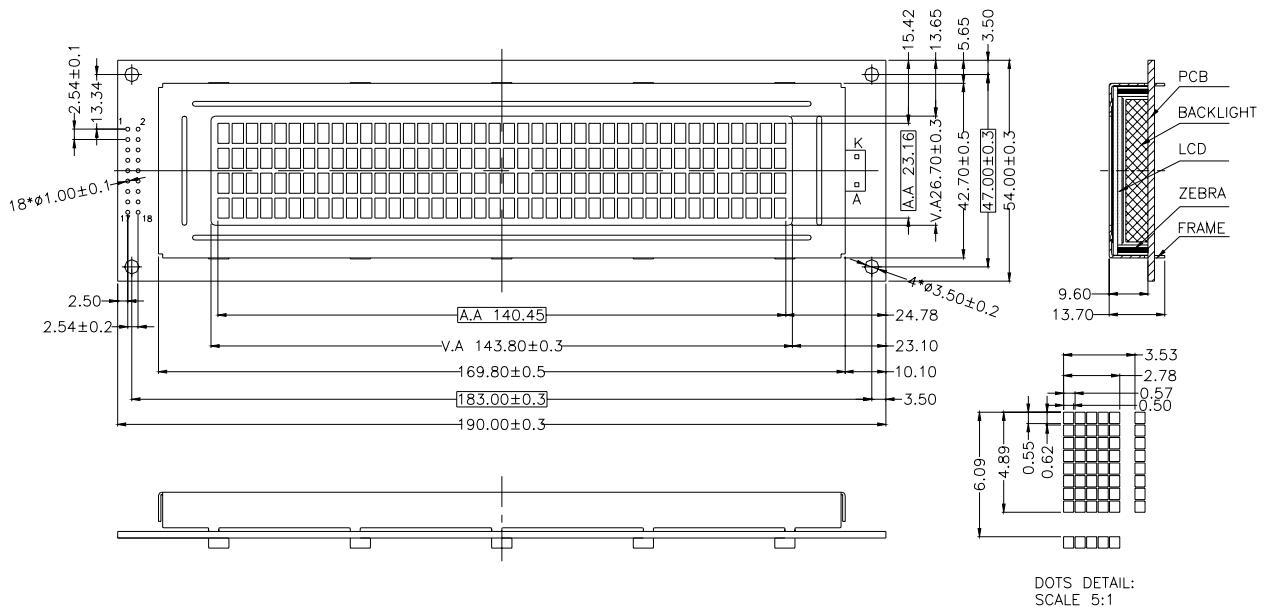

REMARKS:  
 1.UNMARKED TOLERANCE IS ±0.3mm.  
 2.ALL MATERIALS COMPLY WITH ROHS.

**5. PIN ASSIGNMENT**

Pin No.	Symbol	Function
1	DB7	Display Data Signal
2	DB6	
3	DB5	
4	DB4	
5	DB3	
6	DB2	
7	DB1	
8	DB0	
9	E1	Read/Write Enable Signal of second ST7066
10	R/W	Read or Write Select Signal
11	RS	Select Display Data ("H") or Instructions ("L")
12	V0	Power Supply for LCD
13	VSS	Ground
14	VDD	Power supply
15	E2	Read/Write Enable Signal of first ST7066
16	NC	NO Connect
17	LED-(K)	Cathode of Backlight
18	LED+(A)	Anode of Backlight

**6. PCB DRAWING AND DESCRIPTION**

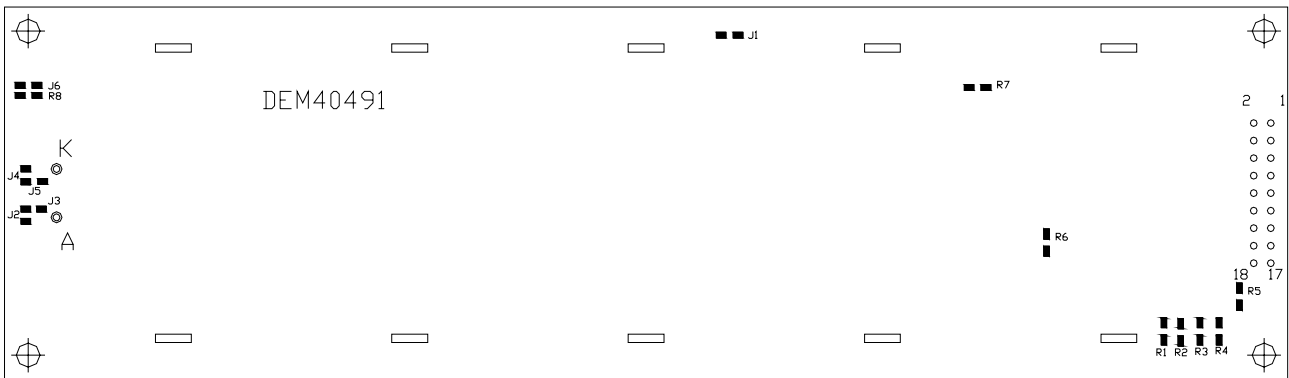

Note: The part no. DEM40491 is printed on the PCB.

**DESCRIPTION:**

**6-1-1. The polarity of the pin 17 and the pin 18:**

J3, J5	J2, J4	LED Polarity	
		17 Pin	18 Pin
open	Each closed	Anode	Cathode
Each closed	open	Cathode	Anode

**6-1-2. The metal-bezel should be on ground when the J1 is solder-Bridge.**

Note: In application J1 is closed.

**6-1-3. The LED resistor should be bridged when the J6 is solder-Bridge.**

Note: In application J6 is open.

**6-1-4. The R8~R11 is the LED resistor.**

Note: In application R8=R9=R10=R11=16 Ohm.



**7. BACKLIGHT & CHARACTERISTICS (Ta=-20~+70°C)**

	SYMBOL	MIN.	TYP.	MAX.	UNIT	CONDITIONS
Forward Voltage	V <sub>f</sub>	--	4.2	4.6	V	If= 500mA
Forward Current	I <sub>f</sub>		500	1000	mA	
Power Dissipation	P <sub>d</sub>		2.05		W	If= 500mA
Reverse Voltage	V <sub>R</sub>			10	V	
Reverse Current	I <sub>R</sub>			5	mA	
Luminous Intensity	I <sub>v</sub>	160	240	320	cd/m <sup>2</sup>	If= 500mA
Luminous Uniformity		70			%	If= 500mA
Emission Wavelength	λ <sub>p</sub>	569		575		If=10mA Ta=25°C Each chip

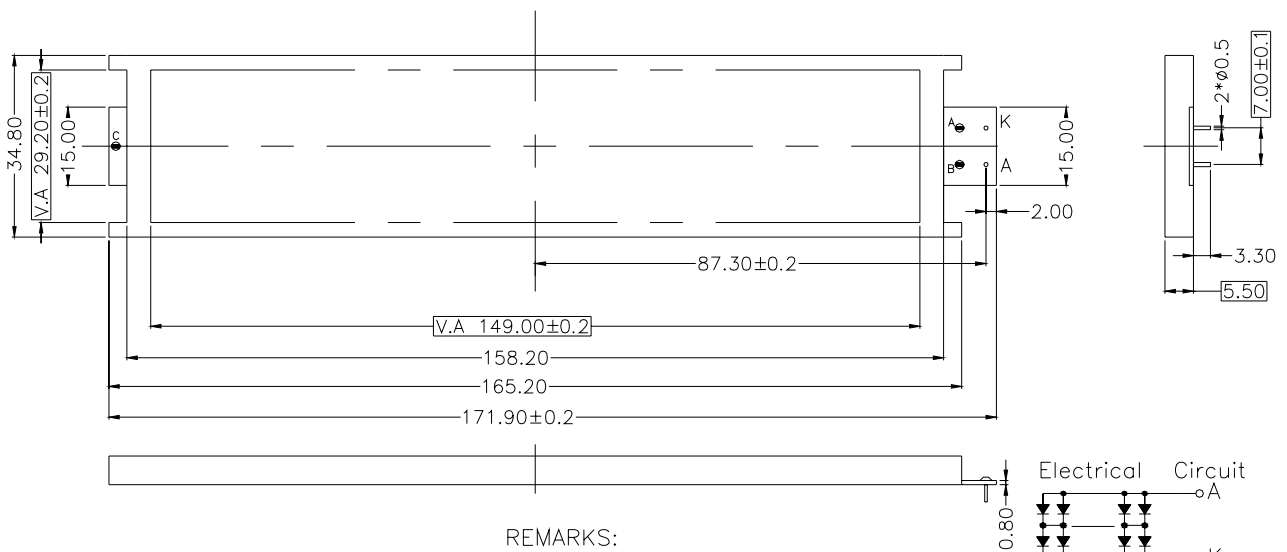

- REMARKS:  
 1. COLOR:YELLOW-GREEN,  
 2. UNMARKED TOLERANCE IS ±0.5.  
 3. THE MATERIAL COMPLY WITH RoHs

**8. DISPLAY DATA RAM (DDRAM)**

	1	2	3	4	5	6	7	8	9	10	11	12	13	14	15	16	17	18	19	20	DISPLAY POSITION
FIRST LINE	00	01	02	03	04	05	06	07	08	09	0A	0B	0C	0D	0E	0F	10	11	12	13	←
SECOND LINE	40	41	42	43	44	45	46	47	48	49	4A	4B	4C	4D	4E	4F	50	51	52	53	←
THIRD LINE	14	15	16	17	18	19	1A	1B	1C	1D	1E	1F	20	21	22	23	24	25	26	27	
FOURTH LINE	54	55	56	57	58	59	5A	5B	5C	5D	5E	5F	60	61	62	63	64	65	66	67	
																					DD RAM ADDRESS

**9. MAXIMUM ABSOLUTE LIMIT**

Item	Symbol	Standard Value	Unit
Power Supply Voltage(1)	V <sub>DD</sub>	-0.3~+7.0	V
Power Supply Voltage(2)	V <sub>LCD</sub>	V <sub>DD</sub> -15.0~V <sub>DD</sub> +0.3	V
Input Voltage	V <sub>IN</sub>	-0.3~V <sub>DD</sub> +0.3	V
Voltage for Backlight	V <sub>LED1</sub>	4~4.5	V
Operating Temperature	T <sub>opr</sub>	-20~+70	°C
Storage Temperature	T <sub>stg</sub>	-30~+80	°C

\*Voltage greater than above may damage to the circuit,

$$V_{DD} \geq V1 \geq V2 \geq V3 \geq V4 \geq V5 .$$

**10. ELECTRICAL CHARACTERISTICS**

**10-1 DC Characteristics** ( $V_{DD}=4.5V\sim 5.5V, T_a=-20\sim +70^{\circ}C$ )

Item	Symbol	Standard Value			Test Condition	Unit
		MIN	TYP	MAX		
Operating Voltage	$V_{DD}$	4.5	5	5.5	-----	V
LCD Driving Voltage	$V_{LCD}$	3.0	4.5	13.0	$V_{DD}-V_5$	V
Supply Current	$I_{DD}$	----	0.35	0.6	$V_{DD}=5V, f_{osc}=270kHz$	mA

**10-2 AC Characteristics** ( $V_{DD}=4.5V\sim 5.5V, T_a=-20\sim +70^{\circ}C$ )

**10-2-1 Write mode (writing data from MPU to ST7066)**

Characteristic	Symbol	Min	Type	Max	Unit	Test PIN
E Cycle Time	$t_C$	1200	---	---	ns	E
E Rise Time	$t_R$	---	---	25	ns	E
E Fall Time	$t_F$	---	---	25	ns	E
E Pulse width	$t_W$	140	---	---	ns	E
Address Setup Time	$t_{SU1}$	0	---	---	ns	R/W,RS,E
Address Hold Time	$t_{H1}$	10	---	---	ns	R/W,RS,E
Data Set-up Time	$t_{SU2}$	40	---	---	ns	DB0~DB7
Data Hold Time	$t_{H2}$	10	---	---	ns	DB0~DB7

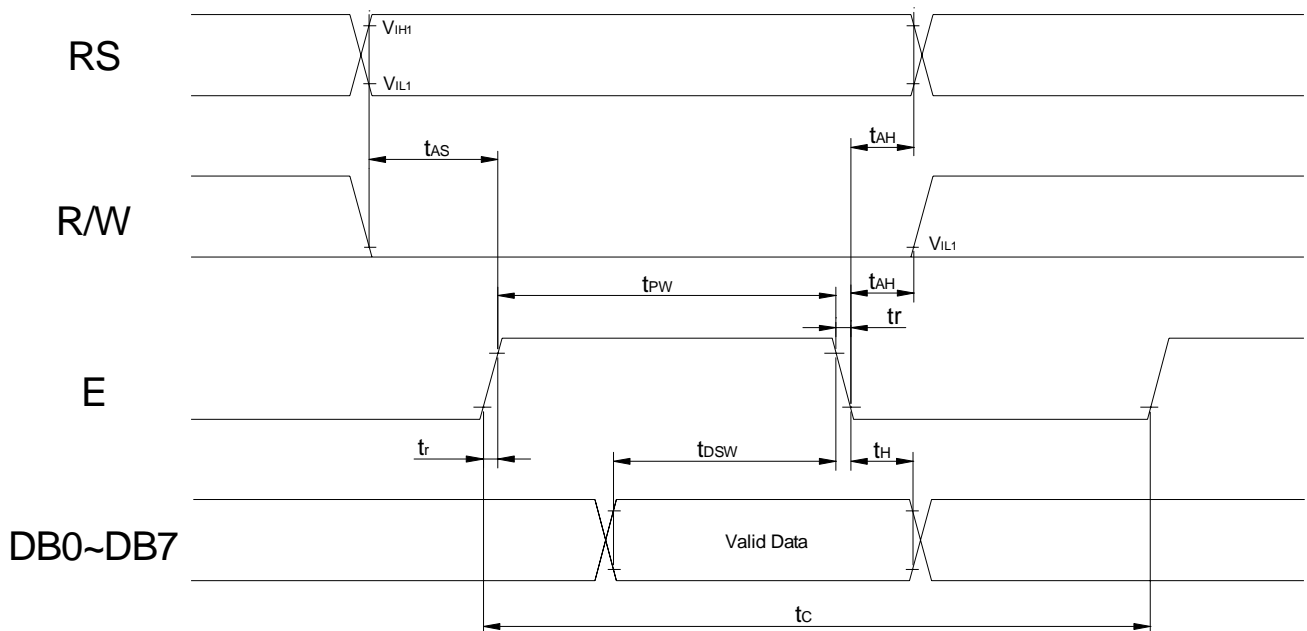

**10-2-2 Read Mode (Reading Data from ST7066 to MPU)**

Characteristic	Symbol	Min	Type	Max	Unit	Test PIN
E Cycle Time	$t_C$	1200	---	---	ns	E
E Rise Time	$t_R$	---	---	25	ns	E
E Fall Time	$t_F$	---	---	25	ns	E
E Pulse width	$t_{PW}$	140	---	---	ns	E
Address Setup Time	$t_{AS}$	0	---	---	ns	R/W,RS,E
Address Hold Time	$t_{AH}$	10	---	---	ns	R/W,RS,E
Data Setup Time	$t_{DDR}$	---	---	100	ns	DB0~DB7
Data Hold Time	$t_H$	10	---	---	ns	DB0~DB7

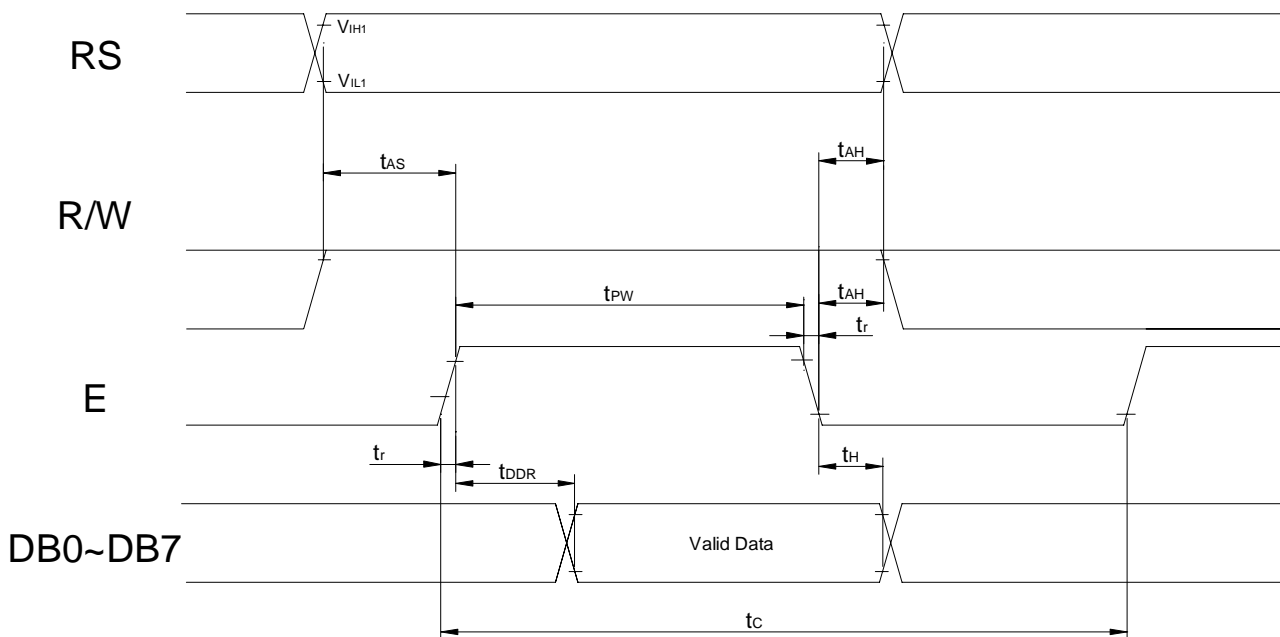

**11. CONTROL AND DISPLAY COMMAND**

Command	RS	R/W	DB7	DB6	DB5	DB4	DB3	DB2	DB1	DB0	Execution time (fosc=270KHz)	Remark
Clear Display	0	0	0	0	0	0	0	0	0	1	1.52ms	Write"20H" to DDRAM. And set DDRAM address to "00H" from AC
Return home	0	0	0	0	0	0	0	0	1	x	1.52ms	Set DDRAM address to "00H" from AC and return cursor to its original position if shifted. The contents of DDRAM are not changed.
Entry mode Set	0	0	0	0	0	0	0	1	I/D	S	37us	Sets cursor move direction and specifies display shift. These operations are performed during data write and read.
Display on/off control	0	0	0	0	0	0	1	D	C	B	37us	D=1: entire display on C=1: cursor on B=1: cursor position on
Cursor or Display Shift	0	0	0	0	0	1	S/C	R/L	x	x	37us	Set cursor moving and display shift control bit, and the direction, without changing DDRAM data.
function Set	0	0	0	0	1	DL	N	F	x	x	37us	DL: interface data is 8/4 bits N: number of line is 2/1 F: font size is 5x11/5x8
Set CGRAM address	0	0	0	1	AC5	AC4	AC3	AC2	AC1	AC0	37us	Set CGRAM address in address counter
Set DDRAM address	0	0	1	AC6	AC5	AC4	AC3	AC2	AC1	AC0	37us	Set DDRAM address in address counter
Read busy flag& address	0	1	BF	AC6	AC5	AC4	AC3	AC2	AC1	AC0	0us	Whether during internal operation or not can be known by reading BF. The contents of address counter can also be read.
Write data to RAM	1	0	D7	D6	D5	D4	D3	D2	D1	D0	37us	Write data into internal RAM (DDRAM/CGRAM)
Read data from RAM	1	1	D7	D6	D5	D4	D3	D2	D1	D0	37us	Read data from internal RAM (DDRAM / CGRAM)

**Note:**

Be sure the ST7066U is not in the busy state (BF=00 before sending an instruction from the MPU to the ST7066U. If an instruction is sent without checking the busy flag, the time between the first instruction and next instruction will take much longer than the instruction time itself. Refer to instruction table for the list of each instruction execution time.

12. STANDARD CHARACTER PATTERN

Upper/Char	Lower/Char	LLLL	LLH	LLHL	LLHH	LHLL	LHLH	LHHL	LHHH	HLLL	HLLH	HLHL	HLHH	HHLL	HHLH	HHHL	HHHH
	CG RAM																
LLLL	(1)			0	1	2	3	4	5	6	7	8	9	A	B	C	D
LLH	(2)			E	F	G	H	I	J	K	L	M	N	O	P	Q	R
LLHL	(3)			S	T	U	V	W	X	Y	Z	[	]	^	_	~	?
LLHH	(4)			!	"	#	\$	%	&	'	(	)	*	+	=	>	@
LHLL	(5)			~	~	~	~	~	~	~	~	~	~	~	~	~	~
LHLH	(6)			~	~	~	~	~	~	~	~	~	~	~	~	~	~
LHHL	(7)			~	~	~	~	~	~	~	~	~	~	~	~	~	~
LHHH	(8)			~	~	~	~	~	~	~	~	~	~	~	~	~	~
HLLL	(1)			~	~	~	~	~	~	~	~	~	~	~	~	~	~
HLLH	(2)			~	~	~	~	~	~	~	~	~	~	~	~	~	~
HLHL	(3)			~	~	~	~	~	~	~	~	~	~	~	~	~	~
HLHH	(4)			~	~	~	~	~	~	~	~	~	~	~	~	~	~
HHLL	(5)			~	~	~	~	~	~	~	~	~	~	~	~	~	~
HHLH	(6)			~	~	~	~	~	~	~	~	~	~	~	~	~	~
HHHL	(7)			~	~	~	~	~	~	~	~	~	~	~	~	~	~
HHHH	(8)			~	~	~	~	~	~	~	~	~	~	~	~	~	~

**13. LCD MODULES HANDLING PRECAUTIONS**

- Please remove the protective foil of polarizer before using.
- The display panel is made of glass. Do not subject it to a mechanical shock by dropping it from a high place, etc.
- If the display panel is damaged and the liquid crystal substance inside it leaks out, do not get any in your mouth. If the substance come into contact with your skin or clothes promptly wash it off using soap and water.
- Do not apply excessive force to the display surface or the adjoining areas since this may cause the color tone to vary.
- The polarizer covering the display surface of the LCD module is soft and easily scratched. Handle this polarize carefully.
- To prevent destruction of the elements by static electricity, be careful to maintain an optimum work environment.
  - Be sure to ground the body when handling the LCD module.
  - Tools required for assembly, such as soldering irons, must be properly grounded.
  - To reduce the amount of static electricity generated, do not conduct assembly and other work under dry conditions.
  - The LCD module is coated with a film to protect the display surface. Exercise care when peeling off this protective film since static electricity may be generated.
- Storage precautions  
When storing the LCD modules, avoid exposure to direct sunlight or to the light of fluorescent lamps. Keep the modules in bags designed to prevent static electricity charging under low temperature / normal humidity conditions (avoid high temperature / high humidity and low temperatures below 0°C). Whenever possible, the LCD modules should be stored in the same conditions in which they were shipped from our company.

**14. OTHERS**

- Liquid crystals solidify at low temperature (below the storage temperature range) leading to defective orientation of liquid crystal or the generation of air bubbles (black or white). Air bubbles may also be generated if the module is subjected to a strong shock at a low temperature.
- If the LCD modules have been operating for a long time showing the same display patterns may remain on the screen as ghost images and a slight contrast irregularity may also appear. Abnormal operating status can be resumed to be normal condition by suspending use for some time. It should be noted that this phenomena does not adversely affect performance reliability.
- To minimize the performance degradation of the LCD modules resulting from caused by static electricity, etc. exercise care to avoid holding the following sections when handling the modules:
  - Exposed area of the printed circuit board
  - Terminal electrode sections